

Newsletter and Technical Tips – December 2005

In this issue:

New Marketing Manager _____	2
Lance Auto Electrics (WA) _____	2
Electric Brake Controller _____	3
Solid State Relay _____	3
Charging 12V Auxiliary Battery _____	4

Lex Clarke celebrates 20 years service of distinction



Pictured above (L to R): LEX CLARKE, Senior Electronics Technician receiving his Twenty Year Service Award from ANTHONY KITTEL, Managing Director, REDARC Electronics, surrounded by the REDARC team.

Redarc took time out on the 11th November 2005 to congratulate and celebrate its first employee, Lex Clarke, attaining 20 years of service. Anthony Kittel, Managing Director said, "It is a great achievement by Lex, he is a valued, loyal employee who provides excellent customer technical support and has a wonderful sense of humour". Lex in reflection on his twenty years, commented as follows:- "When I started at Redarc in 1985, the business was called Labservice, making Redarc branded products. It was located in a house in Blackwood, shared with a real estate agent. We had two rooms and a "sleepout" as production areas, the entrance hallway as a store and one room as an office. There were 5 assemblers, 1 store person, a secretary and the owner/manager/engineer. Over the years, need for more space to cater for an ever-growing team prompted moves to a larger house in Reynella, a shed in Lonsdale then a larger building in Lonsdale, which is now filling quickly. Work has always been "interesting and varied" (as the original job advertisement promised). Growing up with the company as well as being closely involved in the development of its increasing product range has enabled me to have the product familiarity needed to provide the service and technical support our customers appreciate. The team environment at Redarc makes it a great place to work. This is demonstrated by the fact that I won't be the only one to reach the 20 year mark".

www.redarc.com.au



NEW MARKETING MANAGER

REDARC are pleased to announce the appointment of David Heydrich (pictured left) to the newly created position of Marketing Manager. David joins us after 16 years of service for Ingram and most recently Ashdown where he has worked in a variety of roles including Accessories Product Manager and Assistant Marketing Manager. David's role will include a wide range of responsibilities including product packaging, attending trade shows, liaising with customers, product promotions and new product opportunities. Redarc's growth has created the opportunity for this new position and demonstrates our ongoing commitment to our loyal customer base. We wish David every success in his new position. If you would like to contact David please email dheydrich@redarc.com.au or call him on (08) 8186 5633.

LANCE AUTO ELECTRICS (WA) long established supporter of REDARC

Neville Lance (proprietor) commenced business on the 16th January 1980 as a mobile auto electrical operator in the wheat-belt area of WA. He established his first premises in October 1980 in Cannington Perth WA at the same location where the business is based today. Neville employed his first apprentice, Dave Walsh in 1982 and Dave remains a loyal employee. Neville is married to Sherrie who plays an active role in the business managing the administration and accounting functions. Neville and Sherrie have three children and their son, Darren, has recently taken up an apprenticeship in the business.

In June 1984, Neville established Lance Distributors and began selling the REDARC product range. Lance Auto Electrics do all varieties of automotive, airconditioning and mining auto electrical work. Neville is a passionate motor racing enthusiast and has been racing speedcars since 1983. He has won numerous titles including WA State Championships in the speedcar division on 5 occasions. He has raced internationally in New Zealand, Japan and USA. He has also raced NASCAR at the Thunderdome at Calder Park Victoria.



Pictured are Neville Lance (far right) and the LANCE Auto Electrics Team

Neville says that he has seen a lot of changes in the Auto Electrical Industry and the knowledge required to work on vehicle electrical/electronic systems is rapidly increasing. Neville has a clear goal for the future... "Get bigger and better and expand the operation." Of the challenges in business, Neville says that "finding Auto Electricians is becoming more difficult and we're always on the lookout for good staff". Good luck Neville and we wish you and your family business, continued success.

If you would like to show your support of REDARC and be featured in our Newsletter please do not hesitate to send us your photos and some information about your business to power@redarc.com.au

www.redarc.com.au

ELECTRIC TRAILER BRAKE CONTROLLER – Technical Tip

Q. When I measure the output voltage from my EB1AX (or EB3AX) on the trailer socket brake pin, with the trailer not plugged in, I read 4-5V. Is this OK?

A. Yes, this is OK. The EB1AX and EB3AX brake controllers have a trailer brake circuit detection LED. (When you plug in the trailer, the green LED should light). If this pin is measured with nothing connected, you will see the trailer brake detection voltage from the LED. This can be checked by connecting a 5W test lamp to the pin while measuring the voltage. This should result in the meter showing 0V and the green LED should light. If you measure the voltage with the trailer plugged in it should also read 0V. For further assistance, please call REDARC on (08) 8186 5633 or email: power@redarc.com.au to discuss.

SOLID STATE RELAY – New Product

REDARC engineers have designed a range of Solid State Relays (SSR) for specialist low voltage DC applications particularly in the mining industry.

WHY:

- (i) Normal electro-mechanical relays don't cope well with high switching rates (finite life).
- (ii) Sometimes the coil current is too high to be driven directly from a vehicle computer.
- (iii) The electro-mechanical activation can be noisy and cause inconvenience to the user.
- (iv) The solid state relay has better resistance to vibration, shock and harsh environmental conditions.
- (v) No voltage spikes are generated on the control line when using a solid state relay.

HOW:

- (i) The solid state relays incorporate 'mosfets' as the switching device with inbuilt short circuit and over temperature protection.
- (ii) The solid state relay is manufactured for dual 12V and 24V DC applications.
- (iii) The package is the standard 5 pin automotive relay style mounting.
- (iv) A microprocessor can also be used to provide great flexibility to set time and voltage sensing variability.

EXAMPLES:

- (1) A 25A solid state relay was designed to operate truck spot lights as electromechanical relays were deemed unreliable.
- (2) A reed switch on a cabinet door was unable to operate a conventional relay due to arcing of the reed switch contacts and the comparatively high current draw of a conventional relay coil. A solid state relay resulted in no arcing of the contacts and the control was less than 1 mA which was within the rating of the reed switch. The pins are shown below:-

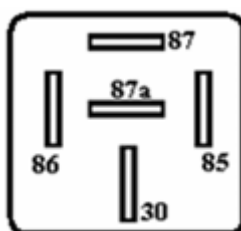

- PIN30.....+12V or 24V supply (for both outputs) from ignition.
- PIN87.....Main output to locker lights (20A max) from PIN30
- PIN87a..... Alarm output (0.5A max) from PIN30
- PIN86.....+12V or 24V from park lights.
- PIN85.....Ground from reed switch to turn on outputs (draws approx 1mA).

*For further assistance, please call REDARC on (08) 8186 5633
or email: power@redarc.com.au to discuss.*

www.redarc.com.au

CHARGING 12V AUXILIARY BATTERY – Technical Tip

The Standard series of Redarc's Charge Equalisers (eg. CE20) have an output which is half the input voltage. This makes it ideal for charging the "bottom" battery (battery connected to ground) in a 24volt battery bank. This allows 12volts to be drawn from this point without the batteries becoming unequally charged.

A common scenario today that Redarc are assisting customers with, is when the customer has a 12volt auxiliary battery mounted on a trailer, a long distance from the 24v start & run battery bank. In this application you would use the CE20-13.8 Charge Equaliser. The CE20-13.8 has a fixed 13.8volts output voltage that ensures the auxiliary battery is fully charged. For best results in this situation you would install the Charge Equaliser close as possible to the 12volt battery to minimise the effect of voltage drop on long wires. The input current on a CE20 (or any of the other higher amperage models) is only about 60% of the output current. So this would mean that the voltage drop on the long input wire will only be 60% of what the voltage drop would have been on a long output wire.

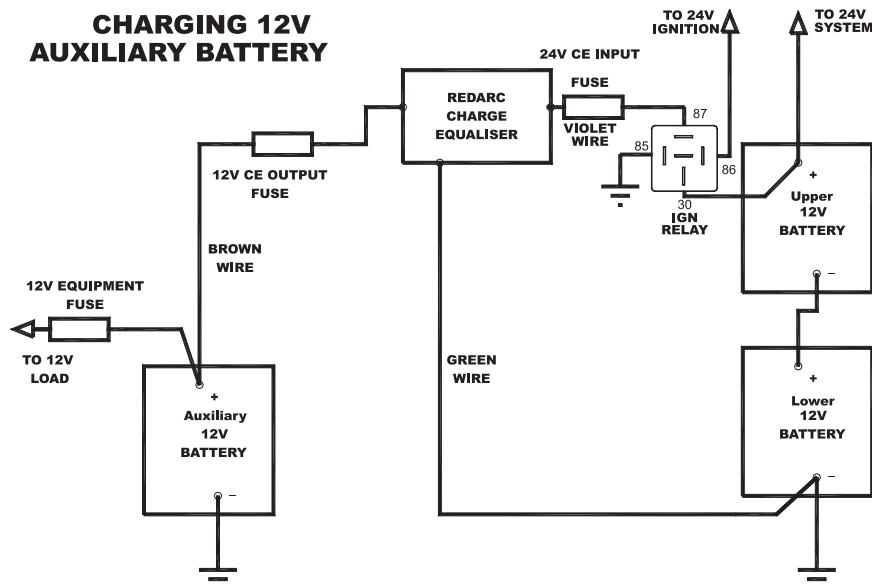

The diagram above shows the wiring of an auxiliary battery using an ignition relay in the 24 volt input wire to the Charge Equaliser. This allows you to draw off the auxiliary battery without flattening the start battery whilst the vehicle is not running. The Redarc range of Charge Equalisers have a high current capability & fast transient response. They are ideally suited to loads requiring a safe, clean & stable 12volt supply. They also are suited for variable current loads such as winches, motors, lamps & fridges as the 12volt supply is taken direct from the lower 12volt battery.

For further assistance, please call REDARC on (08) 8186 5633 or email: power@redarc.com.au to discuss.

The **Festive Season** is near and all of us at **REDARC** would like to take this opportunity to thank you for your support over the past year and wish all of our customers a **Merry Christmas and prosperous New Year**. Our last working day for 2005 will be on Thursday, 22nd December, 2005 and we will recommence after the New Year on Monday, 9th January, 2006.