

GEN750-1 500 SERIES

Laboratory Power Supplies: 750 - 1500 Watts



Features

- High power density 750 - 1500W in 1U rack
- Universal input 85 - 264VAC
- Power Factor Correction 0.99
- Output voltage up to 600V, current up to 200A
- Built in RS232/RS485 interface - standard
- Last Setting Memory: Front Panel Lockout
- Advanced Parallel reports, with up to four units
- Reliable encoders for voltage and current adjustment
- Constant voltage/constant current operation
- Parallel operation with Active Current Sharing
- Independent remote ON/OFF
- Lab View and Lab Windows drivers

General Specifications

Input Voltage:	85 - 264VAC, 120 - 370VDC
Power Factor:	0.99
Harmonics:	EN61000-3-3
Output V/A:	Voltage up to 600VDC, current up to 200A
Output Power:	750 - 1500 watts
Over Current Protection:	Overcurrent 0-105% constant current output shutdown when power supply changes from CV to CC user selectable
Over Voltage Protection:	Inverter Shutdown. Manual reset by recycling AC input or by Output button
Over Temp. Protection:	User selectable, latched or non-latched
EMI:	EN55022-B conducted
Immunity:	EN61000-4
Safety:	EN60950, UL1950 approvals
Operating Temp:	0°C to +50°C at 100% load
Cooling:	Built-in fan (front to rear) zero stacking
AC Input Connector:	750W models: IEC320 socket 1500W models: screw terminals
DC Output Connector:	6V to 60V models: bus bars 80V to 600V models: screw terminals
Dimensions/Weight: (W x H x D)	1U x 19in Rack mounting - 7 to 9 Kg 423 x 43.6 x 432.8mm (excluding connectors and handles)

Description

The **GEN750W** and **GEN1500W** are just two excellent series of laboratory power supplies that are part of a family of units that offer output power from 750W to 15KW.

More and more applications no longer require just a fixed static voltage. Modern test-systems have to vary voltage and current limit during the operation and, additionally they should be able to monitor and store the results on the run.

The innovative design of the GEN Series is based on micro-controllers and encoders that give you great performance and high reliability.

The RS-232/RS-485 interface which is standard on all models, enables you to implement these units easily in any automatic test equipment. With SPCI commands, they can easily be addressed from any graphical user interface for process control, for example Lab View or any computer language.

Test Systems using the IEEE-488 bus to control up to 31 slaves over RS-485 daisy-chain with only the Master needing to be equipped with IEEE interface.

• For more detailed information on the GEN750-1500W series, visit our website. Manual and full application details also available from our website

Options

IEEE:	IEEE 488.2 (GPIB) Interface
IS510:	Voltage Programming Isolated Analog Interface
IS420:	Current Programming Isolated Analog Interface
LAN:	LAN interface
- H:	Optional 750W Half Rack width
GEN - Z0005454:	GEN Series 19in SLIDES

Application Examples:

Automotive

- Component Burn-in
- Fuel Cell
- Lamp Testing
- Component Development

Semi-conductor

- Burn-in
- Deposition
- Ion Implantation

Medical

- X-Ray
- Oncology
- MRI
- Magnets
- Gradient Amplifiers

Aerospace & Defence

- RF Communication
- Satellite Test Systems
- Materials Research
- ATE Systems

Test & Measurement

- Large ATE Systems
- Component Test
- Analytical Instruments
- Module Burn-in
- Component Burn-in

Laser

- Medical
- Marking
- Cutting
- Diode Burn-in

GEN750-1500 SERIES

Laboratory AC/DC Supplies: 750 - 1500 Watts

Model 750W	Output		Power W
	V	A	
GEN6 - 100	0 - 6V	100A	600W
GEN8 - 90	0 - 8V	90A	720W
GEN12.5 - 60	0 - 12.5V	60A	750W
GEN20 - 38	0 - 20V	38A	760W
GEN30 - 25	0 - 30V	25A	750W
GEN40 - 19	0 - 40V	19A	760W
GEN60 - 12.5	0 - 60V	12.5A	750W
GEN80 - 9.5	0 - 80V	9.5A	760W
GEN100 - 7.5	0 - 100V	7.5A	750W
GEN150 - 5	0 - 150V	5A	750W
GEN300 - 2.5	0 - 300V	2.5A	750W
GEN600 - 1.3	0 - 600V	1.3A	780W

Model 1500W	Output		Power W
	V	A	
GEN6 - 200	0-6V	200A	1200W
GEN8 - 180	0-8V	180A	1440W
GEN12.5 - 120	0-12.5V	120A	1500W
GEN20 - 76	0-20V	76A	1520W
GEN30 - 50	0-30V	50A	1500W
GEN40 - 38	0-40V	38A	1520W
GEN50 - 30	0-50V	30A	1500W
GEN60 - 25	0-60V	25A	1500W
GEN80 - 19	0-80V	19A	1520W
GEN100 - 15	0-100V	15A	1500W
GEN150 - 10	0-150V	10A	1500W
GEN300 - 5	0-300V	5A	1500W
GEN600 - 2.6	0-600V	2.6A	1560W

Front Panel Description

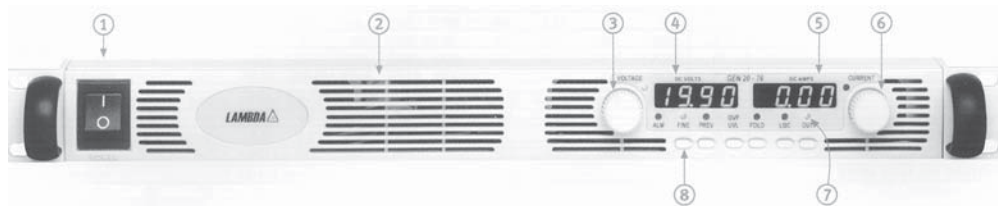

- AC On/Off
- Air intake allows zero stacking for maximum system flexibility and power.
- Reliable encoder controls Output Voltage and sets Address.
- Volt Meter shows Output Voltage and directly displays OVP, UVL and Address settings.
- Amp Meter also displays Baud Rate.
- Reliable encoder controls Output Current and sets Baud rate.
- Function/Status LED's:
 - Alarm • Fine Control • Preview Settings • Foldback Mode • Remote Mode • Output On
- Pushbuttons allow flexible user configuration for the following:
 - Coarse and Fine Voltage and Current Adjustment of Output
 - Preview Settings and Set Voltage while in Current Mode or with Output OFF
 - Set OVP and UVL Limits • Set Current Foldback
 - Local/Remote mode and select Address and Baud Rate • Output ON/OFF and Auto/Safe Start Mode

Rear Panel Description



- Remote/Local Output Voltage Sense Connections
- Dip Switches select 0-5V or 0-10V Programming and other functions.
- DB25 (Female) connector allows (non-isolated) Analog Programme and Monitor as well as other functions.
- RS485 Out to other Genesys Power Supplies.
- RS232/RS485 IN Remote Serial Programming.
- Output Terminals are rugged bus bars for 6-60V Output. Higher output voltage models have a terminal block connector.
- Exit air assures reliable operation when zero stacked.
- Wide-range input 85 - 265 VAC continuous, 47/63Hz with Active Power Factor Correction (0.99).
AC Input Connector 750W: IEC320, 1500W: Screw Terminal model shown.
- Position for Optional Isolated Analog Programming or GPIB Digital Interface model shown

GEN2.4KW SERIES

Laboratory Power Supplies: 2.4KW

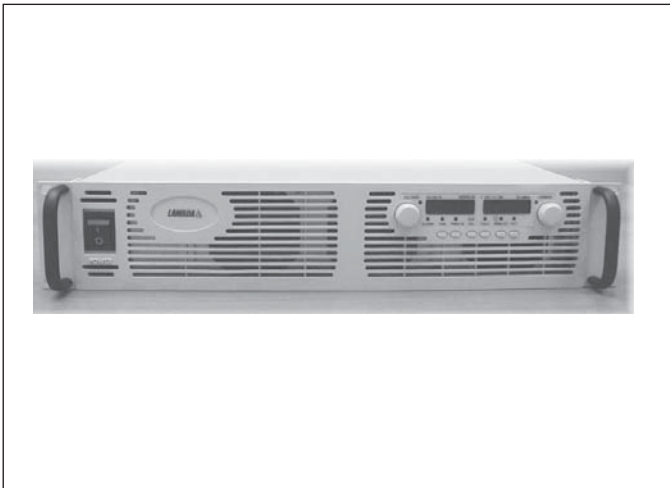

Features

- High power density 2.4KW in 1U Rack
- 1 phase 240VAC or 3 phase 208VAC
- Power Factor Correction 0.99
- Output voltage up to 600V, current up to 300A
- Built in RS232/RS485 interface - standard
- Last Setting Memory: Front Panel Lockout
- Advanced Parallel reports, with up to four units
- Reliable encoders for voltage and current adjustment
- Constant voltage/constant current operation
- Parallel operation with Active Current Sharing
- Independent remote ON/OFF
- Lab View and Lab Windows drivers

General Specifications

Input Voltage:	1 phase: 230VAC (170-265) Code: 1P200 3 phase: 208 VAC (170-265) Code: 3P208
Power Factor:	0.99
Harmonics:	EN61000-3-3
Output V/A:	Voltage up to 600VDC, current up to 300A
Output Power:	2.4KW
Over Current Protection:	Overcurrent 0-105% constant current output shutdown when power supply changes from CV to CC user selectable
Over Voltage Protection:	Inverter Shutdown. Manual reset by recycling AC input or by Output button
Over Temp. Protection:	User selectable, latched or non-latched
EMI:	EN55022-A conducted
Immunity:	EN61000-4
Safety:	EN60950, UL1950 approvals
Operating Temp:	0°C to +50°C at 100% load
Cooling:	Built-in fan (front to rear) zero stacking possible
AC Input Connector:	Phoenix screw terminals
DC Output Connector:	8V to 100V models: bus bars 150V to 600V models: Phoenix wire clamp type
Dimensions/Weight: (W x H x D)	1U x 19in Rack mounting - 10Kg 423 x 43.6 x 485mm (excluding connectors and handles)

Description

The **GEN2.4KW** series of laboratory power supplies are part of a family of units that offer output power from 750W to 15KW.

More and more applications no longer require just a fixed static voltage. Modern test-systems have to vary voltage and current limit during the operation and, additionally they should be able to monitor and store the results on the run.

The innovative design of the GEN Series is based on micro-controllers and encoders that give you great performance and high reliability.

The RS-232/RS-485 interface which is standard on all models, enables you to implement these units easily in any automatic test equipment. With SPCI commands, they can easily be addressed from any graphical user interface for process control, for example Lab View or any computer language.

Test Systems using the IEEE-488 bus to control up to 31 slaves over RS-485 daisy-chain with only the Master needing to be equipped with IEEE interface.

- **For more detailed information on the GEN2.4KW series, visit our website. Manual and full application details also available from our website**

Options

IEEE:	IEEE 488.2 (GPIB) Interface
IS510:	Voltage Programming Isolated Analog Interface
IS420:	Current Programming Isolated Analog Interface
LAN:	LAN interface
GEN - Z0005454:	GEN Series 19in SLIDES

Application Examples:

Automotive

- Component Burn-in
- Fuel Cell
- Lamp Testing
- Component Development

Semi-conductor

- Burn-in
- Deposition
- Ion Implantation

Medical

- X-Ray
- Oncology
- MRI
- Magnets
- Gradient Amplifiers

Aerospace & Defence

- RF Communication
- Satellite Test Systems
- Materials Research
- ATE Systems

Test & Measurement

- Large ATE Systems
- Component Test
- Analytical Instruments
- Module Burn-in
- Component Burn-in

Laser

- Medical
- Marking
- Cutting
- Diode Burn-in

GEN2.4KW SERIES

Laboratory Power Supplies: 2.4KW

Model	Output		Power W
	V	A	
GEN8 - 300	0 - 8V	0 - 300A	2400W
GEN10 - 240	0 - 10V	0 - 240A	2400W
GEN16 - 150	0 - 16V	0 - 150A	2400W
GEN20 - 120	0 - 20V	0 - 120A	2400W
GEN30 - 80	0 - 30V	0 - 80A	2400W
GEN40 - 60	0 - 40V	0 - 60A	2400W

Model	Output		Power W
	V	A	
GEN60 - 40	0 - 60V	0 - 40A	2400W
GEN80 - 30	0 - 80V	0 - 30A	2400W
GEN100 - 24	0 - 100V	0 - 24A	2400W
GEN150 - 16	0 - 150V	0 - 16A	2400W
GEN300 - 8	0 - 300V	0 - 8A	2400W
GEN600 - 4	0 - 600V	0 - 4A	2400W

Front Panel Description



1. ON/OFF Switch.
2. Air intake allows zero stacking for maximum system flexibility and power density.
3. Reliable encoder controls Output Voltage, Address, OVP and UVL settings.
4. Volt Display shows Output Voltage and directly displays OVP, UVL and Address settings.
5. Reliable encoder controls Output Current and sets Baud rate and Advanced Parallel mode.
6. Current Display shows Output Current and displays Baud rate. Displays total current in Parallel Master/Slave Mode.
7. Function/status LEDs: • Alarm • Fine control • Preview Settings • Foldback Mode • Remote Mode • Output On.
8. Pushbuttons allow flexible user configuration:
 - Coarse and Fine adjustment of Output Voltage Current and Advanced Parallel Master or Slave Select
 - Preview settings and set Voltage/Current with Output OFF, Front Panel Lock • Parallel Master/Slave
 - Set OVP and UVL Limits • Set Current Foldback Protection
 - Go to Local Mode and select Address and Baud rate. • Output ON/OFF and Auto Re-start/Safe - Start Mode.

Rear Panel Description



1. Remote/Local Output Voltage Sense Connections.
2. DIP Switches select 0-5V or 0-10V Programming and other functions.
3. DB25 (Female) connector allows (Non-isolated) Analog Programme and Monitor and other functions.
4. RS-485 OUT to other Genesys™ Power Supplies.
5. RS-232/RS-485 IN Remote Serial Programming.
6. Output Connections: Rugged busbars (shown) for up to 100V Output: wire clamp connector for Outputs >100V.
7. Exit air assures reliable operation when zero stacked.
8. Input: 230VAC Single Phase (shown), 208VAC Three Phase, 50/60Hz. AC Input Connector: Phoenix P/N: FRONT-4-H-7.62
9. Optional Interface Position for IEEE 488.2 SCPI (shown), or Isolated Analog Interface or LAN interface.
10. Auxiliary Output Voltage.

GEN3.3KW SERIES

Laboratory Power Supplies: 3.3KW

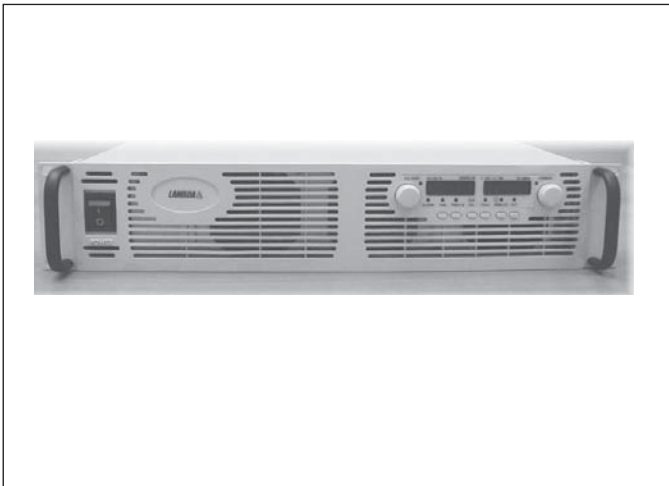

Features

- High power density 3.3Kw in 2U Rack
- 1 phase 240VAC or 3 phase 415VAC input
- Power Factor Correction 0.94
- Output voltage up to 600V, current up to 400A
- Built in RS232/RS485 interface - standard
- Last Setting Memory: Front Panel Lockout
- Advanced Parallel reports, with up to four units
- Reliable encoders for voltage and current adjustment
- Constant voltage/constant current operation
- Parallel operation with Active Current Sharing
- Independent remote ON/OFF
- Lab View and Lab Windows drivers

General Specifications

Input Voltage:	1 phase: 230VAC (170-265) Code: 1P200 3 phase: 208 VAC (170-265) Code: 3P208 3 phase: 415VAC (342-460) Code: 3P400
Power Factor:	0.94
Harmonics:	EN61000-3-3
Output V/A:	Voltage up to 600VDC, current up to 400A
Output Power:	3.3KW
Over Current Protection:	Overcurrent 0-105% constant current output shutdown when power supply changes from CV to CC user selectable
Over Voltage Protection:	Inverter Shutdown. Manual reset by recycling AC input or by Output button
Over Temp. Protection:	User selectable, latched or non-latched
EMI:	EN55022-A conducted
Immunity:	EN61000-4
Safety:	EN60950, UL1950 approvals
Operating Temp:	0°C to +50°C at 100% load
Cooling:	Built-in fan (front to rear) zero stacking possible
AC Input Connector:	Power Combicon with strain relief
DC Output Connector:	8V to 80V models: bus bars 150V to 600V models: Phoenix wire clamp type
Dimensions/Weight: (W x H x D)	2U x 19in Rack mounting - 13 to 15 Kg 423 x 88 x 443mm (excluding connectors and handles)

Description

The **GEN3.3KW** is part of a family of units that offer output power from 750W to 15KW.

More and more applications no longer require just a fixed static voltage. Modern test-systems have to vary voltage and current limit during the operation and, additionally they should be able to monitor and store the results on the run.

The innovative design of the GEN Series is based on micro-controllers and encoders that give you great performance and high reliability.

The RS-232/RS-485 interface which is standard on all models, enables you to implement these units easily in any automatic test equipment. With SPCI commands, they can easily be addressed from any graphical user interface for process control, for example Lab View or any computer language.

Test Systems using the IEEE-488 bus to control up to 31 slaves over RS-485 daisy-chain with only the Master needing to be equipped with IEEE interface.

- **For more detailed information on the GEN3.3Kw series, visit our website. Manual and full application details also available from our website**

Options

IEEE:	IEEE 488.2 (GPIB) Interface
IS510:	Voltage Programming Isolated Analog Interface
IS420:	Current Programming Isolated Analog Interface
LAN:	LAN interface
GEN - Z0005454:	GEN Series 19in SLIDES

Application Examples:

Automotive

- Component Burn-in
- Fuel Cell
- Lamp Testing
- Component Development

Semi-conductor

- Burn-in
- Deposition
- Ion Implantation

Medical

- X-Ray
- Oncology
- MRI
- Magnets
- Gradient Amplifiers

Aerospace & Defence

- RF Communication
- Satellite Test Systems
- Materials Research
- ATE Systems

Test & Measurement

- Large ATE Systems
- Component Test
- Analytical Instruments
- Module Burn-in
- Component Burn-in

Laser

- Medical
- Marking
- Cutting
- Diode Burn-in

GEN3.3KW SERIES

Laboratory AC/DC Supplies: 3.3KW

Model 3.3KW	Output		Power W
	V	A	
GEN8 - 400	0 - 8V	0 - 400A	3200W
GEN10 - 330	0 - 10V	0 - 330A	3300W
GEN15 - 220	0 - 15V	0 - 220A	3300W
GEN20 - 165	0 - 20V	0 - 165A	3300W
GEN30 - 110	0 - 30V	0 - 110A	3300W
GEN40 - 85	0 - 40V	0 - 85A	3300W

Model 3.3KW	Output		Power W
	V	A	
GEN60 - 55	0 - 60V	0 - 55A	3300W
GEN80 - 42	0 - 80V	0 - 42A	3300W
GEN100 - 33	0 - 100V	0 - 33A	3300W
GEN150 - 22	0 - 150V	0 - 22A	3300W
GEN300 - 11	0 - 300V	0 - 11A	3300W
GEN600 - 5.5	0 - 600V	0 - 5.5A	3300W

Front Panel Description

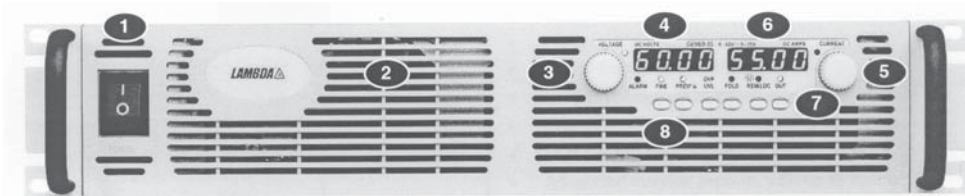

1. ON/OFF Switch.
2. Air intake allows zero stacking for maximum system flexibility and power density.
3. Reliable encoder controls Output Voltage, Address, OVP and UVL settings.
4. Volt Display shows Output Voltage and directly displays OVP, UVL and Address settings.
5. Reliable encoder controls Output Current and sets Baud rate and Advanced Parallel Operation.
6. Current Display shows Output Current and displays Baud rate. Displays total current in Parallel Master/Slave Mode.
7. Function/status LEDs: • Alarm • Fine control • Preview Settings • Foldback Mode • Remote Mode • Output On.
8. Pushbuttons allow flexible user configuration:
 - Coarse and Fine adjustment of Output Voltage/Current and advanced Parallel Master or Slave
 - Preview settings and set Voltage/Current with Output OFF, Front Panel Lock • Parallel Master/Slave
 - Set OVP and UVL Limits • Set Current Foldback Protection • Go to Local Mode and select Address and Baud rate.
 - Output ON/OFF and Auto Re-start/Safe - Start Mode.

Rear Panel Description



1. Remote/Local Output Voltage Sense Connections.
2. DIP Switches select 0-5V or 0-10V Programming and other functions.
3. DB25 (Female) connector allows (Non-isolated) Analog Programme and Monitor and other functions.
4. RS-485 OUT to other Genesys™ Power Supplies.
5. RS-232/RS-485 IN Remote Serial Programming.
6. Output Connections: Rugged busbars (shown) for up to 100V Output: Wire clamp connector for Outputs >100V.
7. Exit air assures reliable operation when zero stacked.
8. Input: 230VAC Single Phase (shown), 208 and 400VAC Three Phase, 50/60Hz.
AC Input Connector: PHOENIX CONTACT Power Combicon PC 6/ ... Series with strain relief.
9. Optional Interface Position for IEEE 488.2 (GPIB) (shown), or Isolated Analog Programming or LAN Interface.

GEN5KW SERIES

Laboratory Power Supplies: 5KW

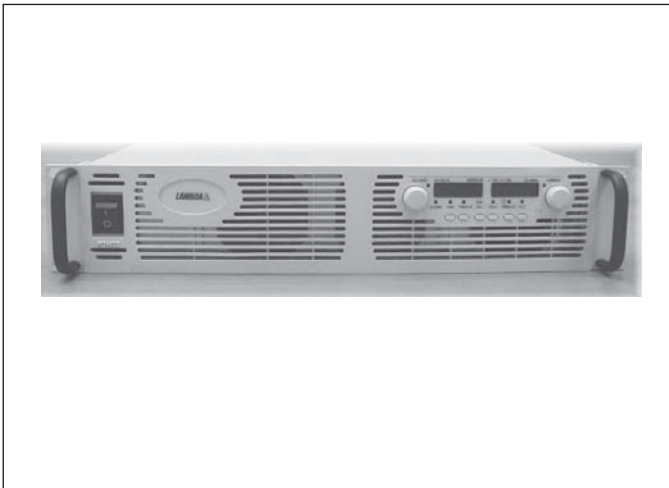

Features

- High power density 5Kw in 2U Rack
- 3 phase 415VAC input
- Power Factor Correction 0.94
- Output voltage up to 600V, current up to 600A
- Built in RS232/RS485 interface - standard
- Last Setting Memory: Front Panel Lockout
- Advanced Parallel reports, with up to four units
- Reliable encoders for voltage and current adjustment
- Constant voltage/constant current operation
- Parallel operation with Active Current Sharing
- Independent remote ON/OFF
- Lab View and Lab Windows drivers

General Specifications

Input Voltage:	3 phase: 208VAC (170-295) Code: 3P208 3 phase: 415VAC (342-460) Code: 3P400
Power Factor:	0.94
Harmonics:	EN61000-3-3
Output V/A:	Voltage up to 600VDC, current up to 600A
Output Power:	5KW
Over Current Protection:	Overcurrent 0-105% constant current output shutdown when power supply changes from CV to CC user selectable
Over Voltage Protection:	Inverter Shutdown. Manual reset by recycling AC input or by Output button
Over Temp. Protection:	User selectable, latched or non-latched
EMI:	EN55022-A conducted
Immunity:	EN61000-4
Safety:	EN60950, UL1950 approvals
Operating Temp:	0°C to +50°C at 100% load
Cooling:	Built-in fan (front to rear) zero stacking possible
AC Input Connector:	Power Combicon with strain relief
DC Output Connector:	8V to 80V models: bus bars 150V to 600V models: Phoenix wire clamp type
Dimensions/Weight: (W x H x D)	2U x 19in Rack mounting - 13 to 15 Kg 423 x 88 x 443mm (excluding connectors and handles)

Description

The **GEN5KW** is part of a family of units that offer output power from 750W to 15KW.

More and more applications no longer require just a fixed static voltage. Modern test-systems have to vary voltage and current limit during the operation and, additionally they should be able to monitor and store the results on the run.

The innovative design of the GEN Series is based on micro-controllers and encoders that give you great performance and high reliability.

The RS-232/RS-485 interface which is standard on all models, enables you to implement these units easily in any automatic test equipment. With SPCI commands, they can easily be addressed from any graphical user interface for process control, for example Lab View or any computer language.

Test Systems using the IEEE-488 bus to control up to 31 slaves over RS-485 daisy-chain with only the Master needing to be equipped with IEEE interface.

- **For more detailed information on the GEN5Kw series, visit our website. Manual and full application details also available from our website**

Options

IEEE:	IEEE 488.2 (GPIB) Interface
IS510:	Voltage Programming Isolated Analog Interface
IS420:	Current Programming Isolated Analog Interface
LAN:	LAN interface
GEN - Z0005454:	GEN Series 19in SLIDES

Application Examples:

Automotive

- Component Burn-in
- Fuel Cell
- Lamp Testing
- Component Development

Semi-conductor

- Burn-in
- Deposition
- Ion Implantation

Medical

- X-Ray
- Oncology
- MRI
- Magnets
- Gradient Amplifiers

Aerospace & Defence

- RF Communication
- Satellite Test Systems
- Materials Research
- ATE Systems

Test & Measurement

- Large ATE Systems
- Component Test
- Analytical Instruments
- Module Burn-in
- Component Burn-in

Laser

- Medical
- Marking
- Cutting
- Diode Burn-in

GEN5KW SERIES

Laboratory AC/DC Supplies: 5KW

Model 5KW	Output		Power W
	V	A	
GEN8 - 600	0 - 8V	0 - 600A	4800W
GEN10 - 500	0 - 10V	0 - 500A	5000W
GEN16 - 310	0 - 16V	0 - 310A	5000W
GEN20 - 250	0 - 20V	0 - 250A	5000W
GEN30 - 170	0 - 30V	0 - 170A	5000W
GEN40 - 125	0 - 40V	0 - 125A	5000W

Model 5KW	Output		Power W
	V	A	
GEN60 - 85	0 - 60V	0 - 85A	5100W
GEN80 - 65	0 - 80V	0 - 65A	5200W
GEN100 - 50	0 - 100V	0 - 50A	5000W
GEN150 - 34	0 - 150V	0 - 34A	5100W
GEN300 - 17	0 - 300V	0 - 17A	5100W
GEN600 - 8.5	0 - 600V	0 - 8.5A	5100W

Front Panel Description

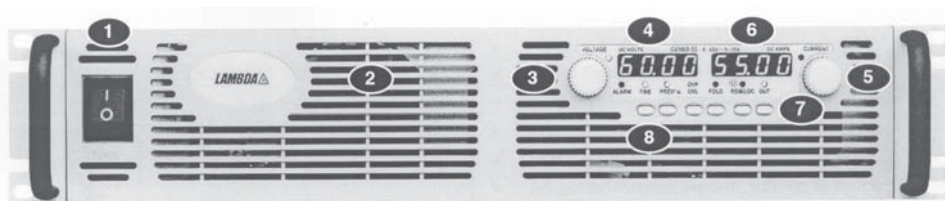

1. ON/OFF Switch.
2. Air intake allows zero stacking for maximum system flexibility and power density.
3. Reliable encoder controls Output Voltage, Address, OVP and UVL settings.
4. Volt Display shows Output Voltage and directly displays OVP, UVL and Address settings.
5. Reliable encoder controls Output Current and sets Baud rate and Advanced Parallel Operation.
6. Current Display shows Output Current and displays Baud rate. Displays total current in Parallel Master/Slave Mode.
7. Function/status LEDs: • Alarm • Fine control • Preview Settings • Foldback Mode • Remote Mode • Output On.
8. Pushbuttons allow flexible user configuration:
 - Coarse and Fine adjustment of Output Voltage/Current and advanced Parallel Master or Slave
 - Preview settings and set Voltage/Current with Output OFF, Front Panel Lock • Parallel Master/Slave
 - Set OVP and UVL Limits • Set Current Foldback Protection • Go to Local Mode and select Address and Baud rate.
 - Output ON/OFF and Auto Re-start/Safe - Start Mode.

Rear Panel Description

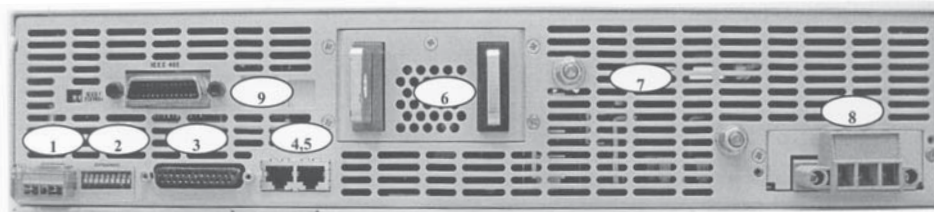

1. Remote/Local Output Voltage Sense Connections.
2. DIP Switches select 0-5V or 0-10V Programming and other functions.
3. DB25 (Female) connector allows (Non-isolated) Analog Programme and Monitor and other functions.
4. RS-485 OUT to other Genesys™ Power Supplies.
5. RS-232/RS-485 IN Remote Serial Programming.
6. Output Connections: Rugged busbars (shown) for up to 100V Output: Wire clamp connector for Outputs > 100V.
7. Exit air assures reliable operation when zero stacked.
8. Input: 230VAC Single Phase (shown), 208 and 400VAC Three Phase, 50/60Hz.
AC Input Connector: PHOENIX CONTACT Power Combicon PC 6/ ... Series with strain relief.
9. Optional Interface Position for IEEE 488.2 (GPIB) (shown), or Isolated Analog Programming or LAN Interface.

GEN 10 - 15KW SERIES

Laboratory Power Supplies: 10 - 15KW

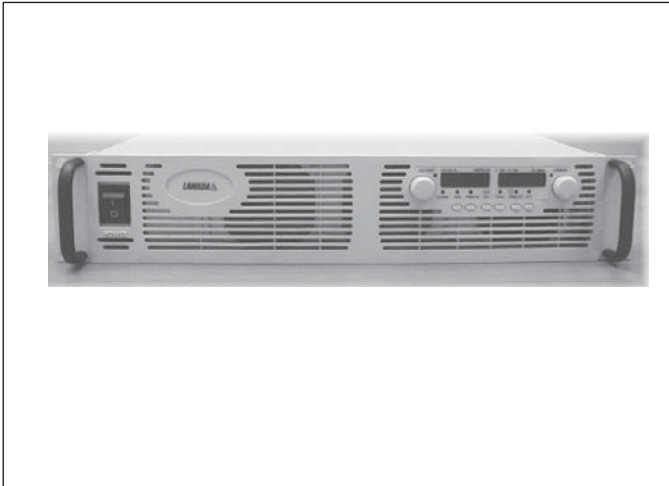

Features

- High power density 10 - 15KW in 3U Rack
- 3 phase input 208VAC or 415VAC
- Power Factor Correction 0.88
- Output voltage up to 600V, current up to 1,000A
- Built in RS232/RS485 interface - standard
- Last Setting Memory: Front Panel Lockout
- Advanced Parallel reports, with up to four units
- Reliable encoders for voltage and current adjustment
- Constant voltage/constant current operation
- Parallel operation with Active Current Sharing
- Independent remote ON/OFF
- Lab View and Lab Windows drivers

General Specifications

Input Voltage:	3 phase: 208 VAC (170-265) Code: 3P208 3 phase: 415VAC (342-460) Code: 3P400 (Phase loss protection)
Power Factor:	0.88
Harmonics:	EN61000-3-3
Output V/A:	Voltage up to 600VDC, current up to 1000A
Output Power:	10KW - 15KW
Over Current Protection:	Overcurrent 0-100% constant current output shutdown when power supply changes from CV to CC user selectable
Over Voltage Protection:	Inverter Shutdown. Manual reset by recycling AC input or by Output button
Over Temp. Protection:	User selectable, latched or non-latched
EMI:	EN55022-A conducted
Immunity:	EN61000-4
Safety:	EN60950, UL1950 approvals
Operating Temp:	0°C to +50°C at 100% load
Cooling:	Built-in fan (front to rear) zero stacking possible
AC Input Connector:	Four threaded studs and terminal cover
DC Output Connector:	Up to 300V models: bus bars Above 300V models: threaded stud terminals
Dimensions/Weight: (W x H x D)	3U x 19in Rack mounting - 43 to 45 Kg 429 x 133 x 584mm (excluding connectors and handles)

Description

The **GEN10Kw** and **GEN15Kw** are just two excellent series of laboratory power supplies that are part of a family of units that offer output power from 750W to 15Kw.

More and more applications no longer require just a fixed static voltage. Modern test-systems have to vary voltage and current limit during the operation and, additionally they should be able to monitor and store the results on the run.

The innovative design of the GEN Series is based on micro-controllers and encoders that give you great performance and high reliability. The RS-232/RS-485 interface which is standard on all models, enables you to implement these units easily in any automatic test equipment. With SPCI commands, they can easily be addressed from any graphical user interface for process control, for example Lab View or any computer language.

Test Systems using the IEEE-488 bus to control up to 31 slaves over RS-485 daisy-chain with only the Master needing to be equipped with IEEE interface.

• For more detailed information on the GEN10 - 15Kw series, visit our website. Manual and full application details also available from our website

Options

IEMD:	GPIB (Multi Drop Master) Interface
IS510:	Voltage Programming Isolated Analog Interface
IS420:	Current Programming Isolated Analog Interface
LAN:	LAN interface

Application Examples:

Automotive

- Component Burn-in
- Fuel Cell
- Lamp Testing
- Component Development

Semi-conductor

- Burn-in
- Deposition
- Ion Implantation

Medical

- X-Ray
- Oncology
- MRI
- Magnets
- Gradient Amplifiers

Aerospace & Defence

- RF Communication
- Satellite Test Systems
- Materials Research
- ATE Systems

Test & Measurement

- Large ATE Systems
- Component Test
- Analytical Instruments
- Module Burn-in
- Component Burn-in

Laser

- Medical
- Marking
- Cutting
- Diode Burn-in

GEN10 - 15KW SERIES

Laboratory Power Supplies: 10 - 15KW

Model 10KW	Output		Power W
	V	A	
GEN7.5 - 1000	0 - 7.5V	0 - 1000A	7.5KW
GEN10 - 1000	0 - 10V	0 - 1000A	10KW
GEN12.5 - 800	0 - 12.5V	0 - 800A	10KW
GEN20 - 500	0 - 20V	0 - 500A	10KW
GEN25 - 400	0 - 25V	0 - 400A	10KW
GEN30 - 333	0 - 33V	0 - 333A	10KW
GEN40 - 250	0 - 40V	0 - 250A	10KW
GEN50 - 200	0 - 50V	0 - 200A	10KW
GEN60 - 167	0 - 60V	0 - 167A	10KW
GEN80 - 125	0 - 80V	0 - 125A	10KW
GEN100 - 100	0 - 100V	0 - 100A	10KW
GEN125 - 80	0 - 125V	0 - 80A	10KW
GEN150 - 66	0 - 150V	0 - 66A	10KW
GEN200 - 50	0 - 200V	0 - 50A	10KW
GEN250 - 40	0 - 250V	0 - 40A	10KW
GEN300 - 33	0 - 300V	0 - 33A	10KW
GEN400 - 25	0 - 400V	0 - 26A	10KW
GEN500 - 20	0 - 500V	0 - 20A	10KW
GEN600 - 17	0 - 600V	0 - 17A	10KW

Model 15KW	Output		Power W
	V	A	
GEN60 - 250	0 - 60V	0 - 250A	15KW
GEN80 - 187.5	0 - 80V	0 - 187A	15KW
GEN100 - 150	0 - 100V	0 - 150A	15KW
GEN125 - 120	0 - 125V	0 - 120A	15KW
GEN150 - 100	0 - 150V	0 - 100A	15KW
GEN200 - 75	0 - 200V	0 - 75A	15KW
GEN250 - 60	0 - 250V	0 - 60A	15KW
GEN300 - 50	0 - 300V	0 - 50A	15KW
GEN400 - 37.5	0 - 400V	0 - 37.5A	15KW
GEN500 - 30	0 - 500V	0 - 30A	15KW
GEN600 - 25	0 - 600V	0 - 25A	15KW

Front Panel Description

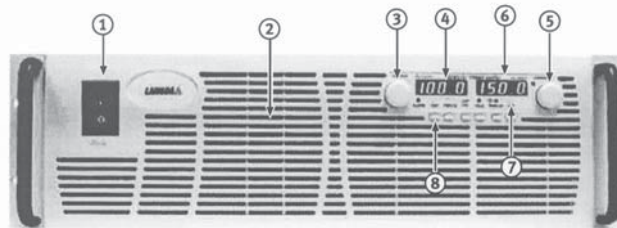

1. ON/OFF Switch.
2. Air intake allows zero stacking for maximum system flexibility and power density.
3. Reliable encoder controls Output Voltage, Address, OVP and UVL settings.
4. Volt Display shows Output Voltage and directly displays OVP, UVL and Address settings.
5. Reliable encoder controls Output Current, sets Baud rate and Advanced Parallel Mode.
6. Current Display shows Output Current and displays Baud rate. Displays total current in Parallel Master/Slave Mode.
7. Function/Status LEDs: • Alarm • Fine Control • Preview Settings • Foldback Mode • Remote Mode • Output On.
8. Pushbuttons allow flexible user configuration:
 - Coarse and Fine adjustment of Output Voltage Current and Advanced Parallel Master or Slave select
 - Preview settings and set Voltage/Current with Output OFF, Front Panel Lock • Parallel Master/Slave • Set OVP and UVL Limits
 - Set Current Foldback Protection • Go to Local Mode and select Address and Baud rate.
 - Output ON/OFF and Auto Re-start/Safe - Start Mode.

Rear Panel Description

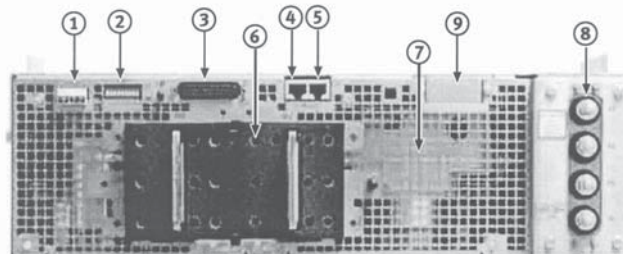

1. Remote/Local Output Voltage Sense Connections.
2. DIP Switches select 0-5V or 0-10V Programming and other functions.
3. DB25 (Female) connector allows (Non-isolated) Analog Programme and Monitor and other functions.
4. RS-485 OUT to other Genesys™ Power Supplies.
5. RS-232/RS-485 IN Remote Serial Programming.
6. Output Connections: Rugged 2 hole busbars (shown) for up to 80V Output. Single hole busbars 100 to 300V Output. Threaded stud terminals above 300V Output.
7. Exit air assures reliable operation when zero stacked.
8. Input Terminals L1, L2, L3, Ground, threaded studs.
9. Optional Interface Position for IEEE 488.2 (GPIB) (shown), Isolated Analog Programming Interface, LAN Interface or USB Interface

ZUP SERIES

Laboratory Power Supplies: 200 - 800 Watts



Features

- Universal input 85-264VAC with PFC
- Output voltage options up to 120VDC
- Output current options up to 132A
- Power factor correction 0.99
- Input current harmonics EN61000-3-2
- Constant voltage/constant current operation
- Built-in RS232 and RS485 interface
- GPIB programming option
- External voltage or resistance programming
- Parallel operation (master/slave) up to 5 units
- Last setting memory with safe restart
- Safety and EMC approvals

General Specifications

Input Voltage:	85 - 264VAC
Power Factor:	Typically 0.95
Harmonics:	EN61000-3-2
Output V/A:	Voltage up to 120VDC, current up to 132A
Output Power:	200 - 800 watts
Over Current Protection:	Over current 0-105% constant current output shutdown when power supply changes from CV to CC, or Foldback. Refer to manual
Over Voltage Protection:	Inverter shutdown, manual reset by recycle AC input or by output button
Over Temp. Protect:	Yes
Programming:	By voltage: 0-4V. Resistance: 0-5K ohm
LED Status:	CC/CV Alarm Foldback Local/Remote ON/OFF
EMI:	EN55022-B conducted
Immunity:	EN61000-4
Safety:	UL3111-1, EN61010-1
Operating Temp:	0°C to +50°C at 100% load
Cooling:	Built-in fan
AC Input Connector:	IEC320 socket
DC Output Connector:	Bus bars
Dimensions & Weight:	200/400W: 70 x 124 x 350mm 2.9/3.2kg (W x H x D) 800W: 140 x 124 x 350mm 5.8kg

Description

The **ZUP** series of laboratory power supplies are one of the most advanced Programmable Power Supplies on the market and are part of a family of units that offer output power from 200W to 15KW

More and more applications no longer require just a fixed static voltage, modern test systems have to vary voltage and current limit during the operation and additionally they should be able to monitor and store the results on the run.

The innovative design of the ZUP series is based on microcontrollers and encoders that give you great performance and high reliability.

The RS-232/RS-485 interface, which is standard on all models, enables you to implement these units easily in any automatic test equipment with SCPI commands, and, easily be addressed from any graphical user interface for process control.

For instruction manual and full application details on the ZUP series, visit our website

Options

GP485:	The GP485 separate controller has all the software and logic required to implement the physical and electrical specifications of the IEEE488 and RS485 standards.
ZUP/L:	Front Panel Output Jacks. Maximum output 60V and 20A
NL200:	Dual Output Case for 200W and 400W models.

Model	Output		Power W
	V	A	
ZUP6 - 33	0 - 6V	0 - 33A	200W
ZUP6 - 66	0 - 6V	0 - 66A	400W
ZUP6 - 132	0 - 6V	0 - 132A	800W
ZUP10 - 20	0 - 10V	0 - 20A	200W
ZUP10 - 40	0 - 10V	0 - 40A	400W
ZUP10 - 80	0 - 10V	0 - 80A	800W
ZUP20 - 10	0 - 20V	0 - 10A	200W
ZUP20 - 20	0 - 20V	0 - 20A	400W
ZUP20 - 40	0 - 20V	0 - 40A	800W
ZUP36 - 6	0 - 36V	0 - 6A	200W
ZUP36 - 12	0 - 36V	0 - 12A	400W
ZUP36 - 24	0 - 36V	0 - 24A	800W
ZUP60 - 3.5	0 - 60V	0 - 3.5A	200W
ZUP60 - 7	0 - 60V	0 - 7A	400W
ZUP60 - 14	0 - 60V	0 - 14A	800W
ZUP80 - 2.5	0 - 80V	0 - 2.5A	200W
ZUP80 - 5	0 - 80V	0 - 5A	400W
ZUP120 - 1.8	0 - 120V	0 - 1.8A	216W
ZUP120 - 3.6	0 - 120V	0 - 3.6A	432W

ZUP SERIES

Laboratory Power Supplies: 200 - 800 Watts

Front Panel

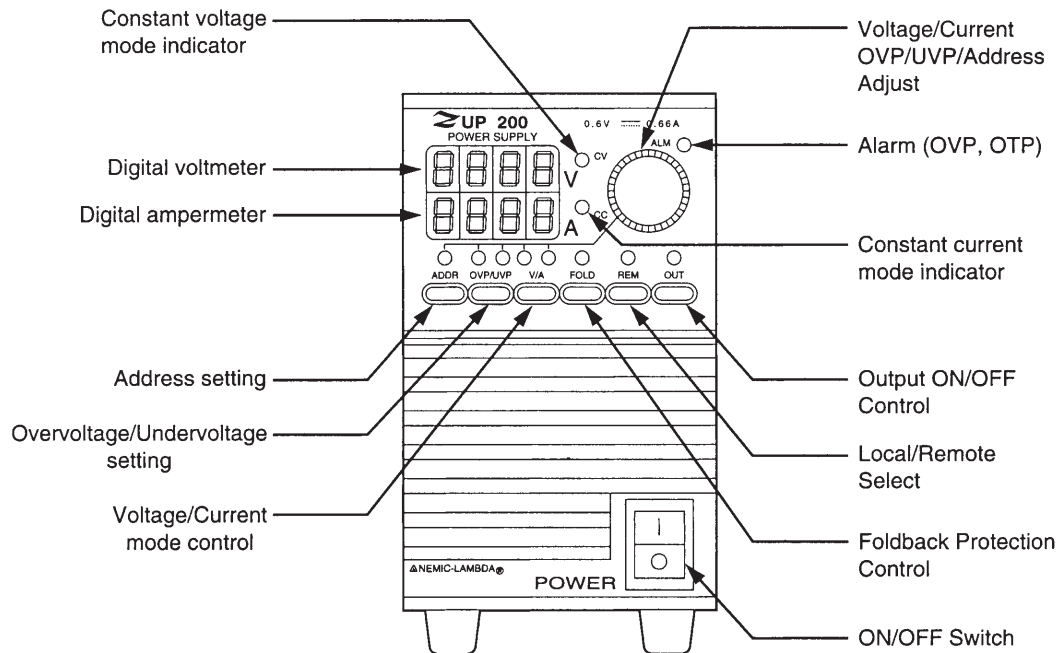

Outline Drawing (200 - 400W)

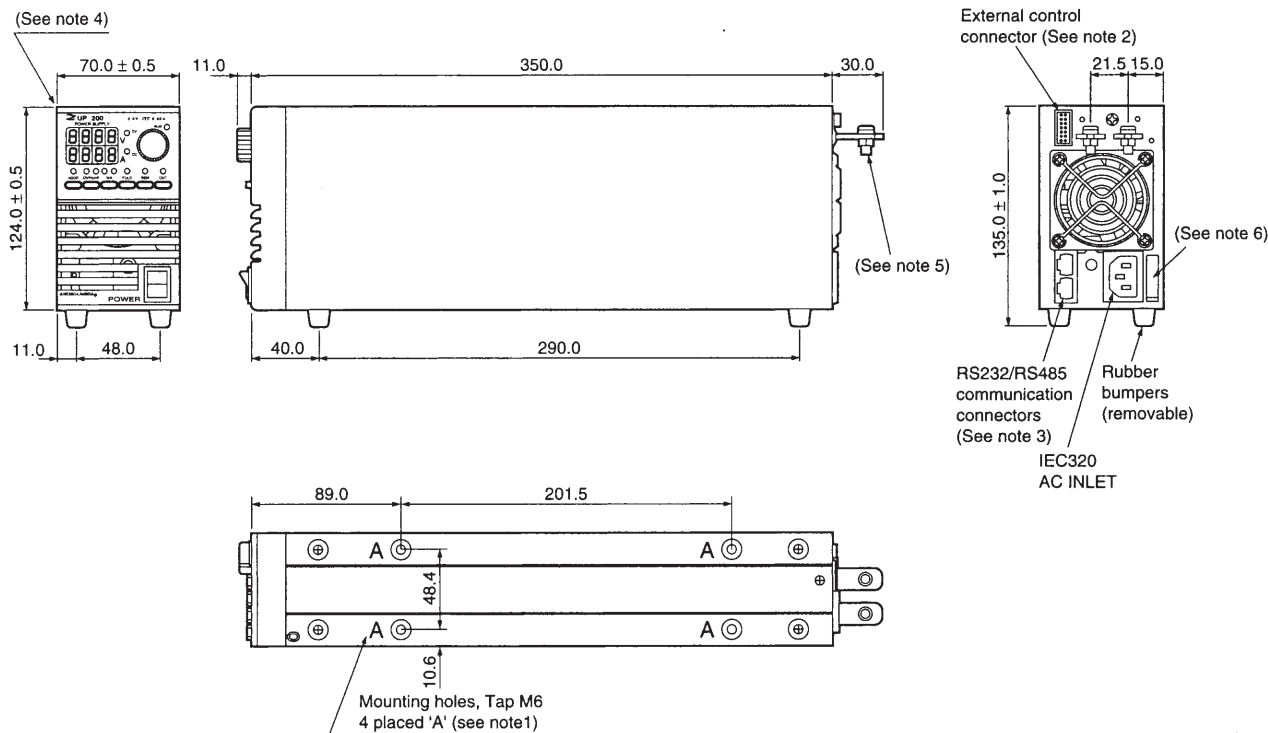

(Unit: mm)

Notes:

1. Mounting screws must not protrude into the power supply more than 6mm.
2. External control connector
Connector: AMP, P/N 102617-5
Receptacle: AMP, P/N 87631-9
Receptacle contacts: AMP, P/N 87523-5(strip form)
P/N 87523-6(loose piece)
- Wire AWG: 24 to 20
Hand tool for wires connection: AMP, P/N: 90202-2

3. RS232/RS485 communication
EIA/EIA-568A, shielded, 8 contacts connectors
4. Model name and output rating are shown here according to the specifications.
5. M6 or M4 screws for load wires connection.
6. Input voltage and current rating are shown here according to the specifications.