



Pure Sine Wave Inverter User's Manual

Table of Contents

1. Important Safety Information	1
1-1 General Safety Precautions	1
1-2 Battery Precautions	1
2. Features	2
2-1 Application	2
2-2 Electrical Performance	3~7
2-3 Mechanical Drawings	8~9
3. Introduction	10
3-1 Front Panel operation	10~12
3-2 Rear Panel operation	13~14
3-3 Protections Features	14
3-4 Installation	15
3-5 Making DC Wiring Connections	16~18
3-6 AC Safety Grounding	19
3-7 Inverter Operation	19
4. Troubleshooting guide	20
5. Maintenance	21
6. Warranty	21~23

1. Important Safety Instructions



WARNING!

Before using the Inverter, read the safety instructions and store them in a safe place.

1-1. General Safety Precautions

- 1-1-1. Do not expose the inverter to rain, snow, spray, bilge or dust. To reduce the risk of hazard, do not cover or obstruct the ventilation openings. Do not install the inverter in a zero-clearance compartment. Overheating may result.
- 1-1-2. To avoid a risk of fire and/or electronic shock, make sure that existing wiring is in good condition and not undersized. Do not operate the inverter with damaged or substandard wiring.
- 1-1-3. Some components in the inverter can cause arcs and sparks. To prevent fire or explosion, do not put batteries, flammable materials, or anything that should be ignition-protected around the inverter.

1-2. Precautions When Working with Batteries

- 1-2-1. If battery acid contacts skin or clothing, you must wash it out with soap and water immediately. If battery acid contacts your eyes, you must wash it out with cold running water for at least 20 minutes and get medical attention immediately.
- 1-2-2. Never smoke or make a spark or flame in the vicinity of the battery or the engine.
- 1-2-3. Do not drop a metal tool on the battery. The resulting spark or short-circuit on the battery or other electrical part may cause an explosion.
- 1-2-4. Remove personal metal items such as rings, bracelets, necklaces, and watches when operating with a lead-acid batteries.
Failure to do so may cause short circuit and very high temperature, which can melt metal items and burn your skin.

2-2. Electrical Performance

Specification	Model No.	
Item	R-12-150S	R-24-150S
Continuous Output Power	150W	
Surge Rating (Max.)	200W	
Input voltage	12V	24V
Output Voltage	220 / 230 / 240V +/- 3%	
Frequency (Switch Selections)	50 / 60Hz +/- 0.05%	
Output Waveform	Pure Sine Wave (THD < 3%)	
Efficiency (full load) Max. *1	87.0%	88.0%
No Load Current Draw (Max.)	0.22A	0.16A
Stand-By Current Draw (Max.)		
Input Voltage Regulation	10.5-15 VDC	21.0-30 VDC
Input Level Indicator	Red LED	
Load Level Indicator		
Failure Indicator		
Protection	Overload, Short Circuit, Reverse Polarity (Fuse), Over / Under Input Voltage, Over Temperature.	
Remote Control Unit	Yes (ON/OFF mode controlled by external switch)	
Safety Cert.	EN60950-1	
EMC	EN55022: 1997 EN55024: 1997 EN61000-3-2: 1998 EN61000-3-3: 1995	e-mark e13 022986
Operating Temperature Range	0 – 40°C	
Storage Temperature Range	-30°C to 70°C	
Cooling	Thermostatically controlled	
Dimensions	200(L)x132(W)x72(H)mm / 7.87(L)x5.20(W)x2.83(H) Inch	
Weight	2.7kg / 5.4 Lbs.	

Note: The specifications are subject to change without notice.

Specification	Model No.	
Item	R-12-350S	R-24-350S
Continuous Output Power	350W	
Maximum Output Power	385W	
Surge Rating (Max.)	700W	
Input voltage	12V	24V
Output Voltage	220 / 230 / 240V +/- 3%	
Frequency (Switch Selections)	50 / 60Hz +/- 0.05%	
Output Waveform	Pure Sine Wave (THD < 3%)	
Efficiency (full load) Max. *1	91.0%	93.0%
No Load Current Draw (Max.)		
Stand-By Current Draw (Max.)		
Input Voltage Regulation	10.5-15 VDC	21.0-30 VDC
Input Level Indicator		
Load Level Indicator		
Failure Indicator	Red LED	
Protection	Overload, Short Circuit, Reverse Polarity (Fuse), Over / Under Input Voltage, Over Temperature.	
Remote Control Unit	Yes (ON/OFF mode controlled by hard wire)	
Safety Cert.	EN60950-1	
EMC	EN55022: 1997 EN55024: 1997 EN61000-3-2: 1998 EN61000-3-3: 1995	e-mark e13 022986
Operating Temperature Range	0 – 40°C	
Storage Temperature Range	-30°C to 70°C	
Cooling	Loading controlled cooling fan	
Dimensions	185(L)x147(W)x60(H)mm / 7.3(L)x5.8(W)x2.36(H) Inch	
Weight	1.4kg / 3.1 Lbs.	

Note: The specifications are subject to change without notice.

Specification	Model No.	
Item	R-12-700S	R-24-700S
Continuous Output Power	700W	
Maximum Output Power	770W	
Surge Rating (Max.)	1400W	
Input voltage	12V	24V
Output Voltage	220 / 230 / 240V +/- 3%	
Frequency (Switch Selections)	50 / 60Hz +/- 0.05%	
Output Waveform	Pure Sine Wave (THD < 3%)	
Efficiency (full load) Max. *1	91.0%	93.0%
No Load Current Draw (Max.)	1.20A	0.60A
Stand-By Current Draw (Max.)	0.25A	0.15A
Input Voltage Regulation	10.5-15 VDC	21.0-30 VDC
Input Level Indicator	Red / Orange / Green LED	
Load Level Indicator		
Failure Indicator	Red LED	
Protection	Overload, Short Circuit, Reverse Polarity (Fuse), Over / Under Input Voltage, Over Temperature.	
Remote Control Unit	CR-6 / CR-7 / CR-8 Optional	
Safety Cert.	EN60950-1	
EMC	EN55022: 1997 EN55024: 1997 EN61000-3-2: 1998 EN61000-3-3: 1995	e-mark e13 022986
Operating Temperature Range	0 – 40°C	
Storage Temperature Range	-30°C to 70°C	
Cooling	Loading controlled cooling fan	
Dimensions	295(L)x180(W)x72(H)mm / 11.61(L)x7.09(W)x2.83(H) Inch	
Weight	2.7kg / 5.4 Lbs.	

Note: The specifications are subject to change without notice.

Specification	Model No.	
Item	R-12-1000S	R-24-1000S
Continuous Output Power	1000W	
Maximum Output Power	1100W	
Surge Rating (Max)	2000W	
Input voltage	12V	24V
Output Voltage	220 / 230 / 240V +/- 3%	
Frequency (Switch Selectable)	50 / 60Hz +/- 0.05%	
Output Waveform	Pure Sine Wave (THD < 3%)	
Efficiency (full load) Max. *1	91.0%	94.0%
No Load Current Draw (Max.)	1.25A	0.65A
Stand-By Current Draw (Max.)	0.25A	0.15A
Input Voltage Regulation	10.5-15 VDC	21.0-30 VDC
Input Level Indicator	Red / Orange / Green LED	
Load Level Indicator		
Failure Indicator	Red LED	
Protection	Overload, Short Circuit, Reverse Polarity (Fuse), Over / Under Input Voltage, Over Temperature.	
Remote Control Unit	CR-6 / CR-7 / CR-8 Optional	
Safety Certification	EN60950-1	
EMC	EN55022: 1997 EN55024: 1997 EN61000-3-2: 1998 EN61000-3-3: 1995	e-mark e13 022694
Operating Temperature Range	0 – 40°C	
Storage Temperature Range	-30°C to 70°C	
Cooling	Loading controlled cooling fan	
Dimensions	383(L)x182(W)x88(H)mm / 15.08(L)x7.17(W)x3.46(H) Inch	
Weight	4 kg / 8.8 Lbs.	

Note: The specifications are subject to change without notice.

Specification	Model No.	
Item	R-12-1500S	R-24-1500S
Continuous Output Power	1500W	
Maximum Output Power	1650W	
Surge Rating (Max)	3000W	
Input voltage	12V	24V
Output Voltage	220 / 230 / 240V +/- 3%	
Frequency (Switch Selectable)	50 / 60Hz +/- 0.05%	
Output Waveform	Pure Sine Wave (THD < 3%)	
Efficiency (full load) Max. *1	90.0%	93.0%
No Load Current Draw (Max)	1.40A	0.70A
Stand-By Current Draw (Max)	0.28A	0.15A
Input Voltage Regulation	10.5-15 VDC	21.0-30 VDC
Input Level Indicator	Red / Orange / Green LED	
Load Level Indicator		
Failure Indicator	Red LED	
Protection	Overload, Short Circuit, Reverse Polarity (Fuse), Over / Under Input Voltage, Over Temperature.	
Remote Control Unit	CR-6 / CR-7 / CR-8 Optional	
Safety Certification	EN60950-1	
EMC	EN55022: 1997 EN55024: 1997 EN61000-3-2: 1998 EN61000-3-3: 1995	e-mark e13 22876
Operating Temperature Range	0 – 40°C	
Storage Temperature Range	-30°C to 70°C	
Cooling	Loading controlled cooling fan	
Dimensions	415(L)x191(W)x88(H)mm / 16.34(L)x7.52(W)x3.46(H) Inch	
Weight	4.8 kg / 10.56 Lbs.	

Note: The specifications are subject to change without notice.

Specification	Model No.	
Item	R-12-2000S	R-24-2000S
Continuous Output Power	2000W	
Maximum Output Power	2200W	
Surge Rating (Max)	4000W	
Input voltage	12V	24V
Output Voltage	220 / 230 / 240V +/- 3%	
Frequency (Switch Selectable)	50 / 60Hz +/- 0.05%	
Output Waveform	Pure Sine Wave (THD < 3%)	
Efficiency (full load) Max. *1	91.0%	94.0%
No Load Current Draw (Max)	2.64A	1.32A
Stand-By Current Draw (Max)	0.60A	0.25A
Input Voltage Regulation	10.5-15 VDC	21.0-30 VDC
Input Level Indicator	Red / Orange / Green LED	
Load Level Indicator		
Failure Indicator	Red LED	
Protection	Overload, Short Circuit, Reverse Polarity (Fuse), Over / Under Input Voltage, Over Temperature.	
Remote Control Unit	CR-6 / CR-7 / CR-8 Optional	
Safety Certification	EN60950-1	
EMC	EN55022: 1997 EN55024: 1997 EN61000-3-2: 1998 EN61000-3-3: 1995	e-mark e13 22846
Operating Temperature Range	0 – 40°C	
Storage Temperature Range	-30°C to 70°C	
Cooling	Loading controlled cooling fan (65□ ON , 45□ OFF)	
Dimensions	422(L)x208(W)x166(H)mm / 16.6(L)x8.18(W)x6.53(H) Inch	
Weight	9 kg / 19.8 Lbs.	

Note: The specifications are subject to change without notice.

Specification	Model No.	
Item	R-12-3000S	R-24-3000S
Continuous Output Power	3000W	
Maximum Output Power	3300W	
Surge Rating (Max)	6000W	
Input voltage	12V	24V
Output Voltage	220 / 230 / 240V +/- 3%	
Frequency (Switch Selectable)	50 / 60Hz +/- 0.05%	
Output Waveform	Pure Sine Wave (THD < 3%)	
Efficiency (full load) Max. *1	90.0%	93.0%
No Load Current Draw (Max)	2.8A	1.5A
Stand-By Current Draw (Max)	0.55A	0.35A
Input Voltage Regulation	10.5-15 VDC	21.0-30 VDC
Input Level Indicator	Red / Orange / Green LED	
Load Level Indicator		
Failure Indicator	Red LED	
Protection	Overload, Short Circuit, Reverse Polarity (Fuse), Over / Under Input Voltage, Over Temperature.	
Remote Control Unit	CR-6 / CR-7 / CR-8 Optional	
Safety Cert.	EN60950-1	
EMC	EN55022: 1997 EN55024: 1997 EN61000-3-2: 1998 EN61000-3-3: 1995	e-mark e13 22845
Operating Temperature Range	0 – 40°C	
Storage Temperature Range	-30°C to 70°C	
Cooling	Loading controlled cooling fan	
Dimensions	452(L)x208(W)x166(H)mm / 17.80(L)x8.18(W)x6.53(H) Inch	
Weight	9.8 kg / 22 Lbs.	

Note: The specifications are subject to change without notice.
*1 : This test condition is normal DC input (13.5V) and Temperature 25 °C.

2-3. Mechanical Drawings

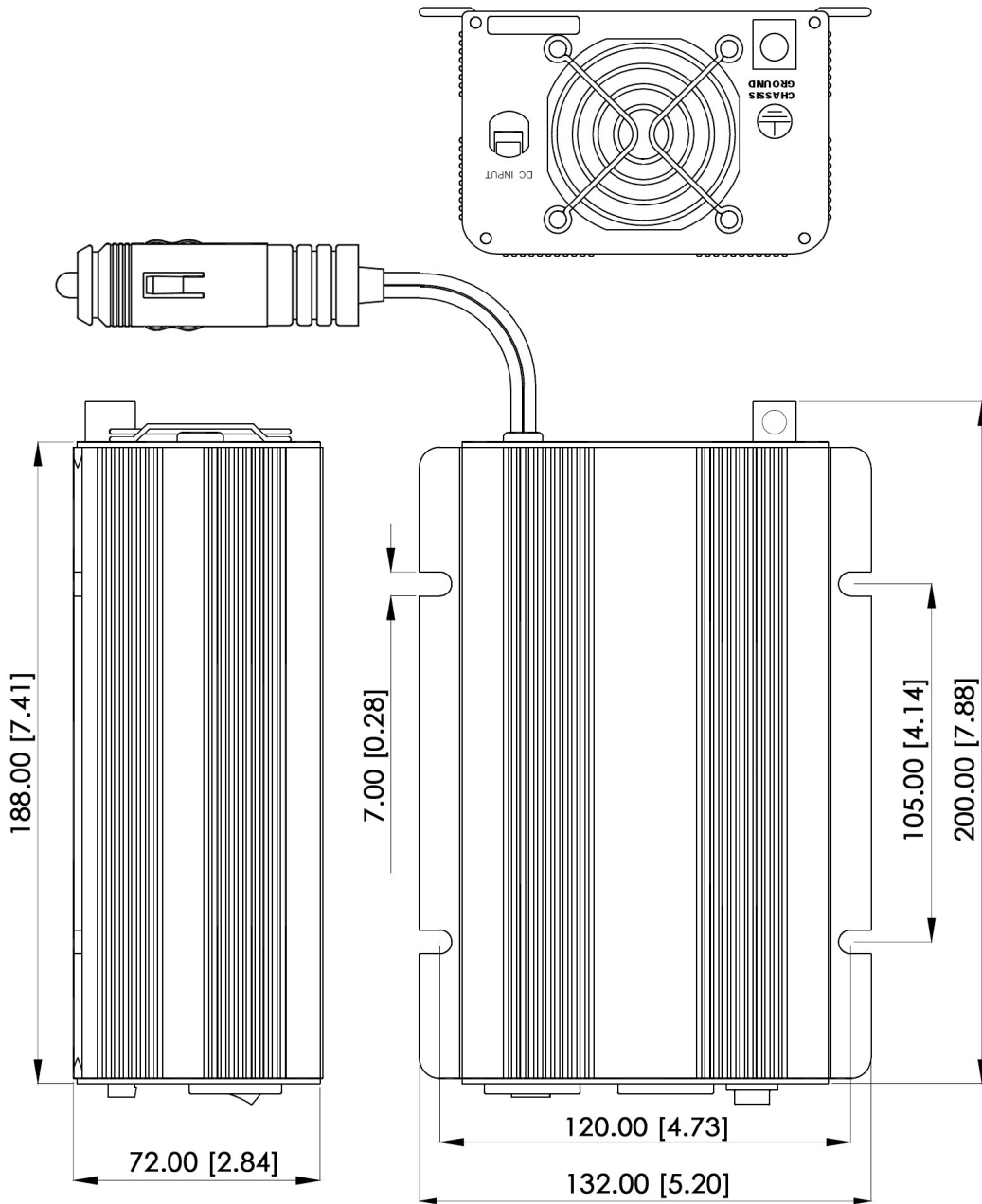

150W

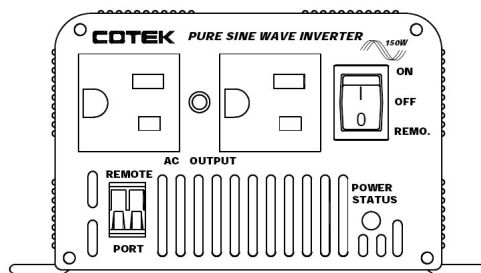

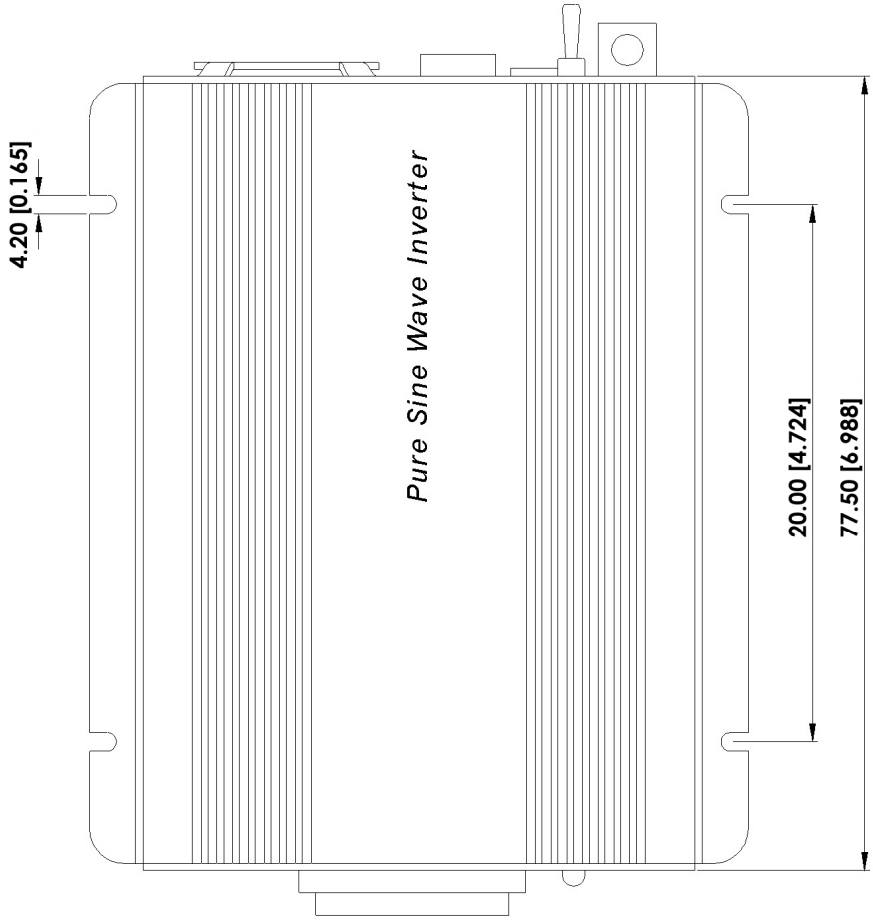
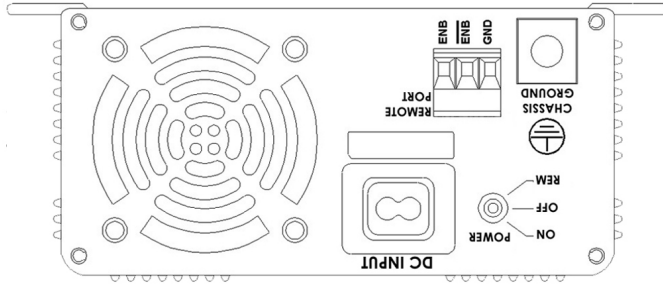

350W

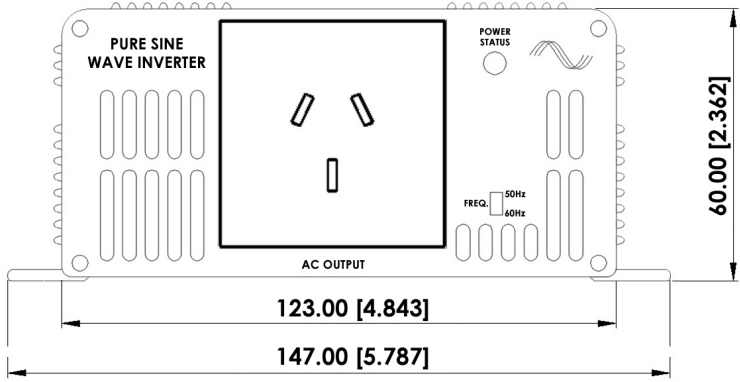

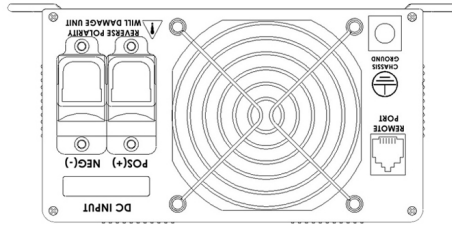

700W, 1000W & 1500W

700W 273.00 [10.75]
1000W 340.00 [13.39]
1500W 370.00 [14.57]

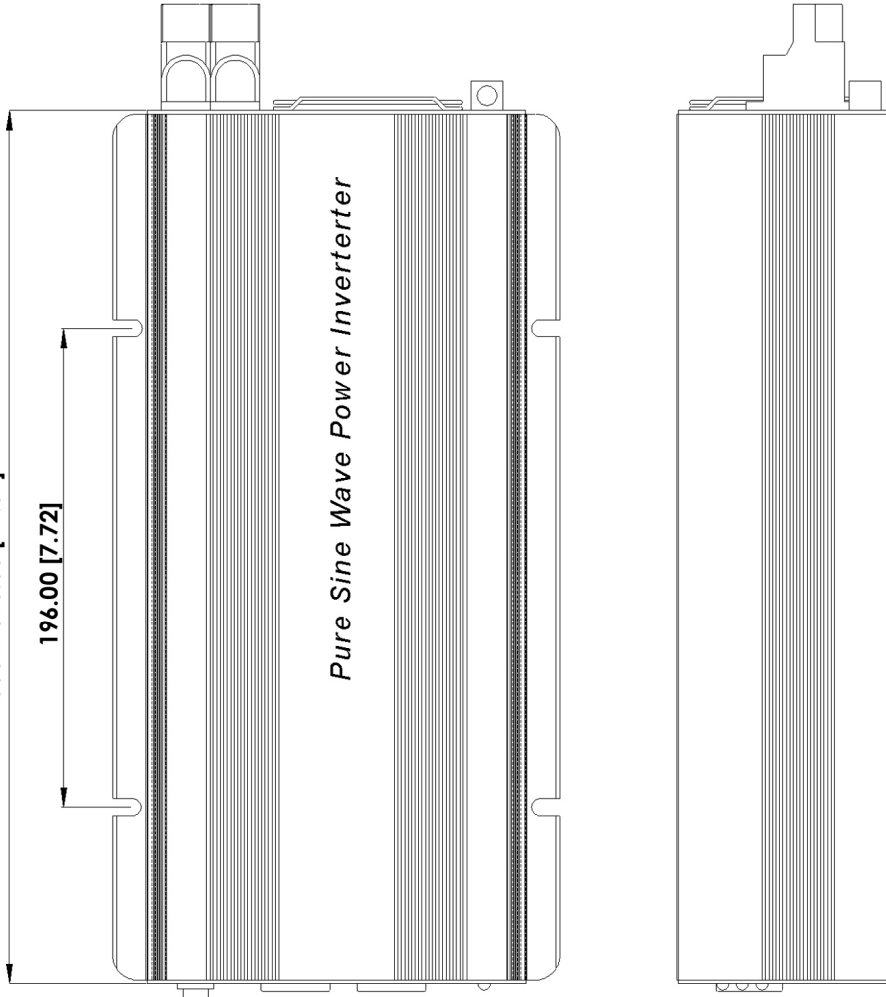

700W 151.00 [5.94]
1000W 154.00 [6.06]
1500W 163.00 [6.42]

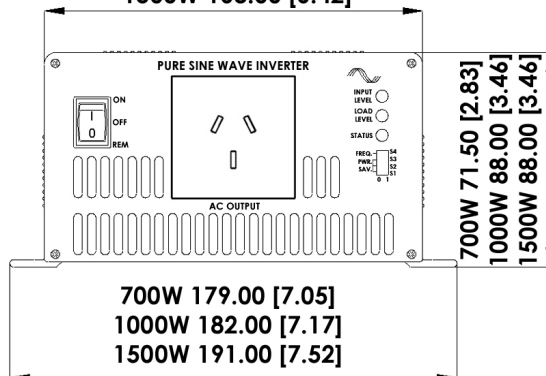

2000W & 3000W

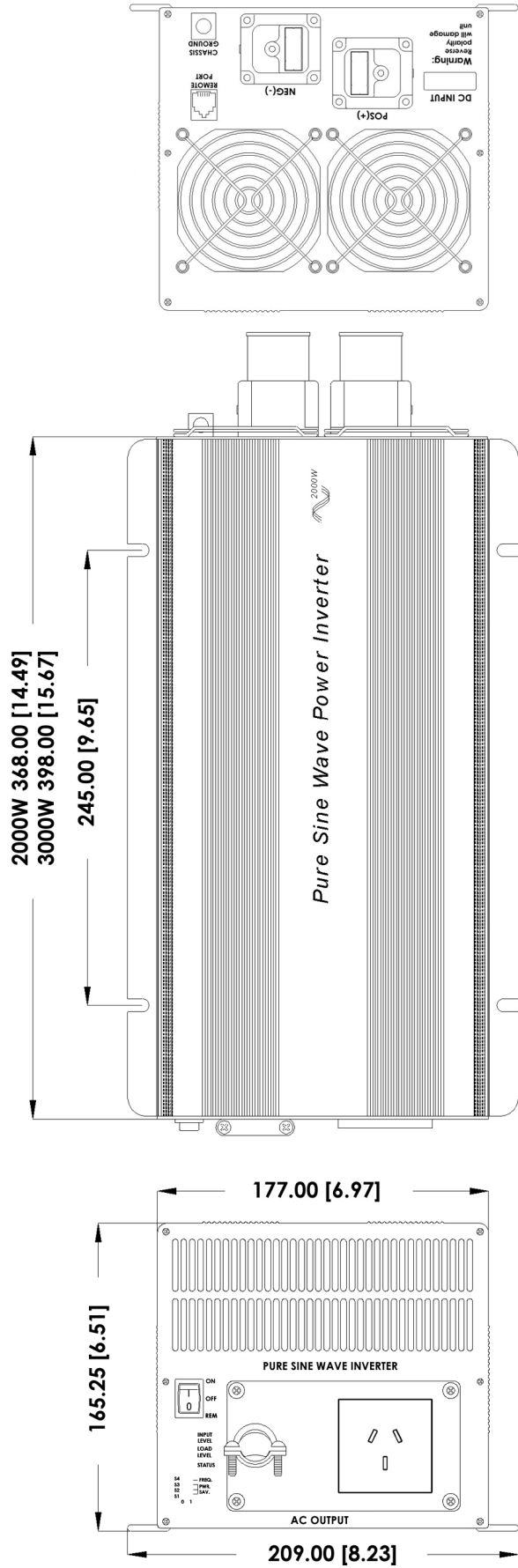

3. Introduction

The Redarc pure sine wave power inverter series is one of the most advanced mobile AC power systems.

For ideal operation from the power inverter, it must be installed and used properly. Please read the instructions of this manual before you install and operate this model.

3-1. Front Panel Operations :

3-1-1. Front view :

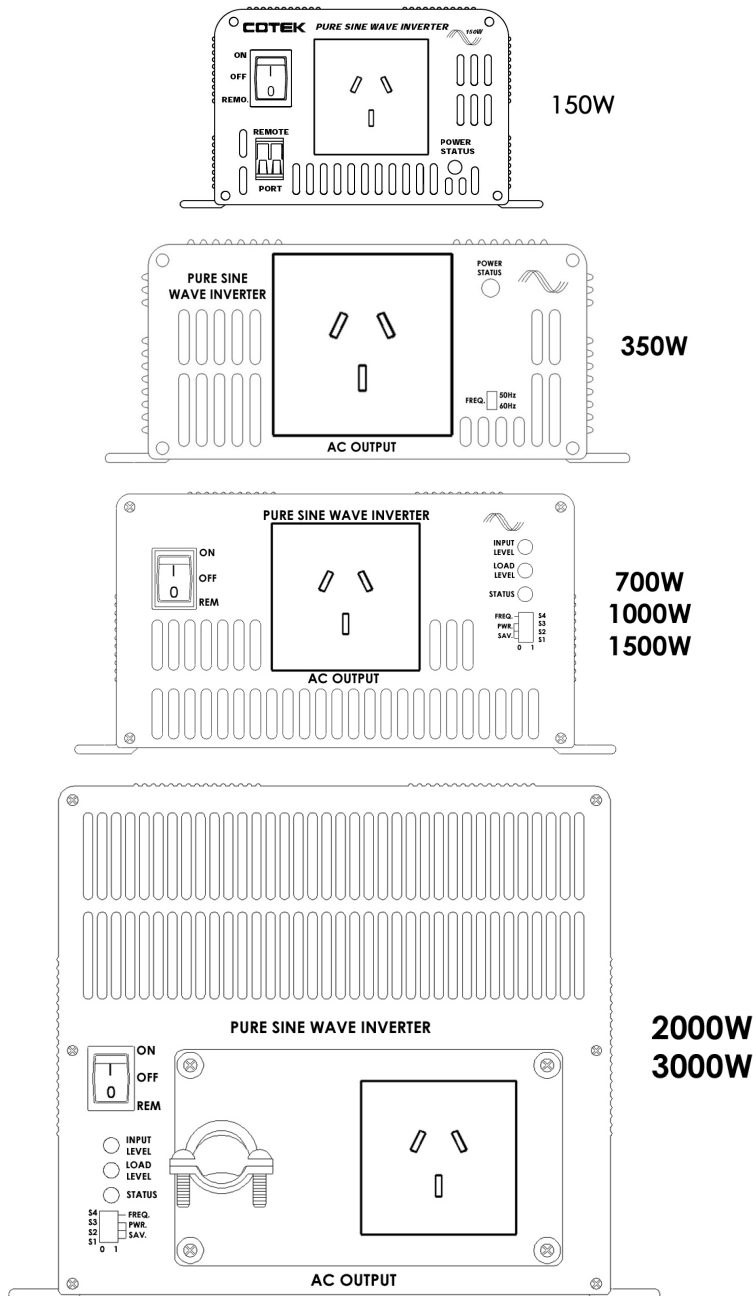

3-1-2. ON / OFF/ REMOTE (Main) switch (700W to 3000W models) :

- a. Before installing the inverter, you need to ensure the main switch is set to "OFF".
- b. Before using the remote unit, you need to ensure the main switch is set to "REMOTE".

3-1-3. Input Level (700W to 3000W models) : Display Input Voltages

LED Status	DC 12V	DC 24V
RED Slow Blink	10.3~10.6	20.5~21.2
RED	10.6~11.0	21.2~21.8
ORANGE	11.0~12.1	21.8~24.1
GREEN	12.1~14.2	24.1~28.6
ORANGE Blink	14.2~15.0	28.6~30.0
OVER RED Blink	15.0↑	30.0↑

3-1-4. Load Level (700W to 3000W models) : Display AC Loads (Watts)

LED status	DARK	GREEN	ORANGE	RED	RED BLINK
700W	0 ~ 56W	56 ~ 230W	230 ~ 525W	525 ~ 672W	Over 672W
1000W	0 ~ 80W	80 ~ 330W	330 ~ 750W	750 ~ 960W	Over 960W
1500W	0 ~ 120W	120 ~ 495W	495 ~ 1125W	1125 ~ 1450W	Over 1450W
2000W	0 ~ 160W	160 ~ 660W	660 ~ 1500W	1500 ~ 1920W	Over 1920W
3000W	0 ~ 240W	240 ~ 990W	990 ~ 2250W	2250 ~ 2880W	Over 2880W

3-1-5. AC Frequency : Selected by "S4" Dip Switch

Frequency	S4
50 HZ	OFF
60 HZ	ON

3-1-6. Status : Display Power & Fault Status

Green LED	LED Signal	Status
Solid	—————	Power OK
Slow Blink	- - - -	Power Saving**
Red LED	LED Signal	Status
Fast Blink	- - - - - - - -	OVP*
Slow Blink	- - - -	UVP*
Intermittent Blink	OTP*
Solid	—————	OLP*

*Note: Refer to Troubleshooting (Section 4) for details on status indication.

**Note: Power Saving mode not available in 200W & 350W models.

3-1-7. Power Saving Mode: Power Saving Mode is adjustable and set by the Dip Switches, S1, S2 and S3 on the front panel.
Example: With the power setting at 15W, a 15W↑ load will make the inverter operate normally, a 15W↓ load will enter into the Power saving mode.

700W	1000W 1500W	2000W 3000W	S1	S2	S3
DISABLE	DISABLE	DISABLE	OFF	OFF	OFF
15W	20W	40W	ON	OFF	OFF
25W	40W	80W	OFF	ON	OFF
40W	55W	125W	ON	ON	OFF
50W	75W	170W	OFF	OFF	ON
65W	95W	210W	ON	OFF	ON
75W	115W	245W	OFF	ON	ON
85W	135W	280W	ON	ON	ON

3-2. Rear Panel Operations :

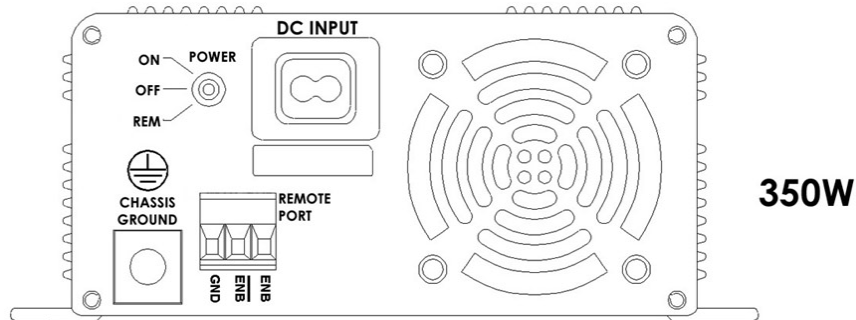

3-2-1. ON / OFF / REMOTE Main Switch 200W & 350W models.

- 3-2-1-1. Before installing the inverter, make sure the main switch must be "OFF".
- 3-2-1-2. Before using the remote unit, make sure the main switch must be "REMOTE".
- 3-2-1-3. Ensure the remote control contact is off.
- 3-2-1-4. Remote Port : Place 0.75mm² and Screw type cable between the remote port and the panel.
- 3-2-1-5. Remote port ON/OFF inverter setup status

Remote Switch Examples.

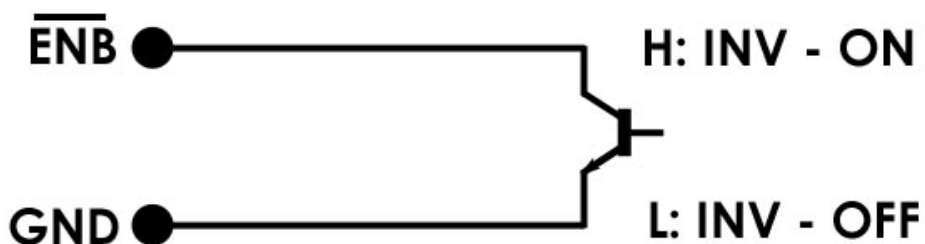
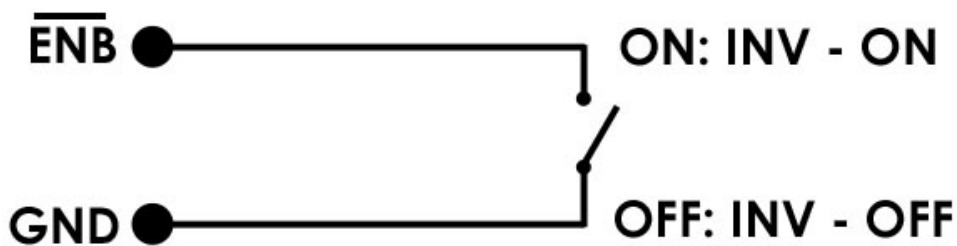

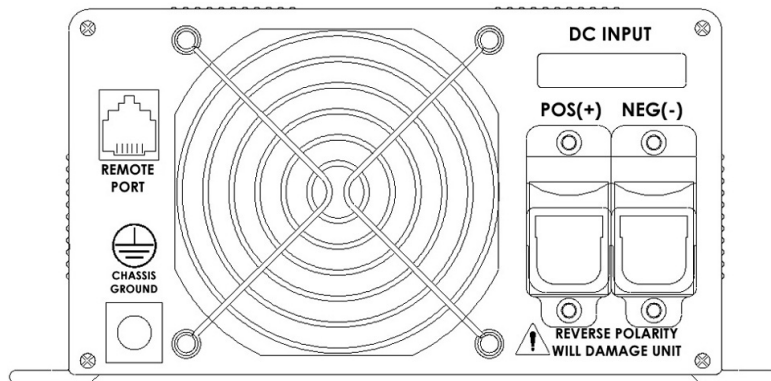

**700W
1000W
1500W**

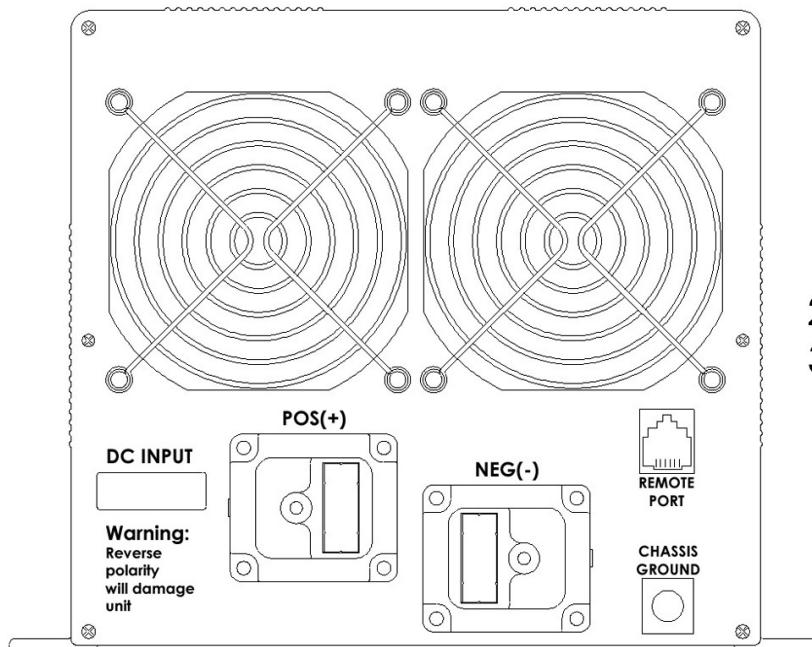

**2000W
3000W**

3-2-2. Remote Port:

All Redarc pure sine wave inverters are compatible with the CR-6 remote control. 700W to 3000W inverters are compatible with the CR-8 remote control.

Before using the remote unit, you need to ensure the main switch is in the "REMOTE" position and the input voltage of the power inverter is the same as it of the remote unit.

3-2-3. Fan Ventilation:

Be sure to keep it a distance (at least 25mm) from surrounding objects.

3-2-4. DC Input Terminal :

Connect DC input terminal to 12V / 24V / 48V battery or the other power sources.

POS(+) represents positive, and NEG(-) represents negative. Reverse polarity connection will blow the internal fuse and may damage the inverter permanently.

Model	DC Input Voltage	
	Minimum	Maximum
12 V	10.5	15.0
24 V	21.0	30.0

3-2-5. Use 7.5mm²/8 B&S (85A) cable to connect Chassis ground with vehicle chassis.



WARNING!
Operating the inverter without a proper ground Connection may cause an electrical hazard.

3-3. Protections Features:

Model	DC Input (VDC)					Over Temperature Protection			
	Over Voltage		Under Voltage Alarm	Under Voltage		INTERIOR		HEAT SINK	
	Shut-down	Restart		Shut-down	Restart	Shut-down	Restart	Shut-down	Restart
12 V	15.3	14.3	11.0	10.2	12.7	70°C	45°C	90°C	60°C
24 V	30.6	28.8	22.0	20.3	25.2				

3-4. Installation :

The power inverter should be installed in an environment that meets the following requirements :

- 3-4-1. Dry – Do not allow water to drip on or enter into the inverter.
- 3-4-2. Cool – Ambient air temperature should be between 0°C and 40°C, the cooler the better.
- 3-4-3. Safe – Do not install the inverter in a battery compartment or other areas where volatile fumes may exist, such as fuel storage areas or engine compartments.
- 3-4-4. Ventilated – Keep the inverter a distance (as least 25mm) away from surrounding objects. Ensure the ventilation shafts on the rear and the bottom of the unit are not obstructed.
- 3-4-5. Dust – Do not install the Inverter in a dusty environments the dust can be inhaled into the unit when the cooling fan is working.
- 3-4-6. Fused – A fuse must be fitted between the battery and the Inverter.
- 3-4-7. Close to batteries – Avoid excessive cable lengths. Do not install the Inverter in the same compartment as batteries. Use the recommended wire lengths and sizes (see section 3-5). Do not mount the Inverter where it will be exposed to the gasses produced by the battery. These gasses are very corrosive, and prolonged exposure will damage the Inverter.



WARNING!

Shock Hazard. Before proceeding further, carefully check that the Inverter is NOT connected to any batteries, and that all wiring is disconnected from any electrical sources. Do not connect the output terminals of the Inverter to an incoming AC source.

3-5. DC Wiring Connections :

The tables below give the recommended cable/conductor cross-sectional area (mm²), and recommended B & S size for a required current across a particular distance. In this case the distance is between the battery and the inverter. It is recommended to choose a cable size close to but larger than required.

NOTE: the cable cross-sectional area will need to be increased, (de-rated), should the cables be bundled with other heat generating cables, thermally insulated or subjected to high ambient temperatures.

(mm ²)		Ampere (A)										
		5	10	20	30	40	50	60	70	80	90	100
Distance (m)	1	1	2	3.5	5	5	5	7.5	10	10	16	16
	2	1	2	3.5	5	5	7.5	10	10	16	16	16
	3	1	2.5	5	5	7.5	7.5	10	16	16	17	25
	4	1	2.5	5	7.5	7.5	10	10	16	16	25	25
	5	1	2.5	5	7.5	10	10	16	16	25	25	25
	6	2	2.5	5	7.5	10	10	16	25	25	25	25
	7	2	2.5	5	7.5	10	10	16	25	25	23	25
	8	2	3.5	7.5	10	10	16	16	25	25	25	25
	9	2	3.5	7.5	10	16	16	25	25	25	25	35
	10	2	3.5	7.5	10	16	16	25	25	25	35	35

(B&S)		Ampere (A)										
		5	10	20	30	40	50	60	70	80	90	100
Distance (m)	1	16	14	12	10	10	10	8	8	8	6	6
	2	16	14	12	10	10	8	8	8	6	6	6
	3	16	14	10	10	8	8	6	6	6	6	4
	4	16	14	10	10	8	8	6	6	6	4	4
	5	16	14	10	8	8	6	6	6	4	4	4
	6	14	14	10	8	6	6	6	4	4	4	4
	7	14	14	10	8	6	6	6	4	4	4	4
	8	14	12	8	8	6	6	4	4	4	4	4
	9	14	12	8	8	6	4	4	4	4	4	2
	10	14	12	8	8	6	4	4	4	4	2	2

3-5-1. Connect the cables to the power input terminals on the rear panel of the inverter. The red terminal represents positive POS(+) and the black terminal represents negative NEG(-). Insert the cables into the terminals and tighten the screw to clamp the wires securely.



WARNING!

Ensure all the DC connections are tight (torque to 11.7 – 13 Nm, 9 – 10 ft-lbs). Loose connections may cause overheat and fire.



WARNING!

The installation of a fuse must be on a positive cable. Failure to place a fuse on “+” cables running between the inverter and battery may cause damage to the inverter and will void warranty.

Also, use only high quality copper wire and keep cable length short, a maximum of 1 - 2 metres.

Battery to inverter cable connection

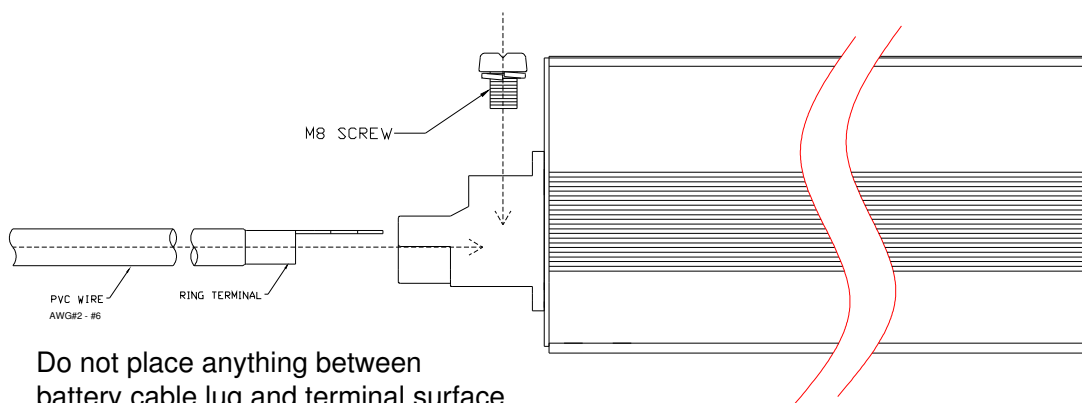

Do not place anything between battery cable lug and terminal surface. Assemble exactly as shown.

3-6. AC Safety Grounding :

Residual Current Devices (RCD) :

Certain installation codes and/or government regulations require the installation of a RCD.

Redarc has tested a number of commercially available RCDs and found that they functioned properly when connected to the output of the Inverter.

NOTE: The AC output ground wire should go to the grounding point for your loads (for example, a distribution panel ground bus).

3-7. Inverter Operation :

To operate the power inverter, use the ON / OFF switch on the Front panel to turn the power on. Then the power inverter is ready to deliver AC power to your loads. If there is several loads, turn them on separately after the inverter is "ON" in order to prevent OVP resulted from the surge power.

3-7-1. Set the power switch to the "ON" position, the buzzer will send out "Beep" sounds at this point. The inverter will now perform self-diagnosis, and the LED indicators will also appear various colors. Finally the buzzer will "Beep" again and the Input Level and Status LED indicators will turn "Green" in color, then the inverter starts to work successfully.

3-7-2. Set the power switch to the OFF position, the inverter will stop and all the LED's go off.

3-7-3. Set the power inverter switch to the ON position and turn the test load on. The inverter should supply power to the load. If you plan to accurately measure the true output R.M.S. voltage of the inverter, a true R.M.S meter must be used to measure the output of the inverter.

4. Troubleshooting :



WARNING!

Do not open or disassemble the Inverter.
Attempting to service the unit yourself may cause the risk of electrical shock or fire.

Problems and Symptoms	Possible Cause	Solutions
"No AC Power Output"		
STATUS illuminates the red LED		
a. Blinking fast	Over input voltage. (OVP)	Check input voltage. Reduce input voltage.
b. Blinking slowly.	Low input voltage. (UVP)	Recharge battery. Check connections and the cable.
c. Blinking Intermittently.	Thermal shutdown. (OTP)	Improve ventilation. Make sure ventilation shafts in the inverter are not obstructed. Lower ambient temperature.
d. Solid ON.	Short circuit or Wiring error. Overload.(OLP)	Check AC wiring for short circuit. Reduce the load.

5. Maintenance :

To keep your inverter operating properly, there is very little maintenance required.

You should clean the exterior periodically with a damp cloth to prevent accumulation of dust and dirt. At the same time, tighten the screws on the DC input terminals.

6. Warranty :

REDARC Electronics warrants to the original purchaser that the product(s) in this booklet ("Product") will be free, under normal use and maintenance, from defects in material and workmanship for a period of TWO YEARS from the date of purchase, subject to the conditions shown below.

6-1. Warranty

Unless otherwise stated in this warranty, Redarc Electronics will at its sole discretion either replace or repair any of the Product that is defective in material or workmanship within the abovementioned period without charge to the original purchaser.

6-2. Other Warranty

Subject to any terms implied by law, this warranty contains the whole of the Redarc Electronics' obligations and any distributor and the agents, officers and employees of such distributor and of Redarc Electronics are not authorised to vary or extend the terms of the warranty. The benefits conferred by this warranty are in addition to the conditions and warranties implied by applicable legislation conferring rights upon consumers, which apply only to the extent to which they may not by law be excluded.

6-3. Exclusions

This warranty shall not apply to, or include, any of the following:

6-3-1. Any defect or failure due to accident, misuse, abuse, movement of the Product to a new site, negligence, non-observance of any of the instructions supplied with the Product including the instructions on the reverse side of this sheet ("Operating Instructions") or local regulations on the part of any user, choice of location, improper installation, configuration or connection, or faulty power supply.

- 6-3-2. If the Product is installed, repaired or serviced by a person who is not a qualified auto electrician or electronics technician, or if non-approved parts have been fitted.
- 6-3-3. Failure to obtain proper maintenance for the Product or any associated equipment or machinery.
- 6-3-4. Failure to pay for the products in full or comply with Redarc Electronics' Trading Terms.
- 6-3-5. If the Product is used other than for any reasonable purpose for which it was manufactured, or is used in a way not specified by Redarc Electronics.
- 6-3-6. If the original purchaser sells, leases or otherwise parts with possession of the Product.
- 6-3-7. Deterioration due to normal use and exposure, including abnormal environmental conditions such as lightning strike, flood and extreme heat.
- 6-3-8. Any freight, packing and insurance expenses relating to transportation of the Product.
- 6-3-9. Any expenses relating to installation and/or removal of the Product.
- 6-3-10. Any damage, indirect or incidental, of whatever nature.

6-4. Limitations

- 6-4-1. Redarc Electronics is not liable for any consequential, indirect or accidental loss or damage or for any service not expressly provided herein (including without limitation liability for any loss or damage caused by a fault in the Product or its external wiring connections) and the liability of Redarc Electronics under this warranty is limited to the repair or replacement of defective material or workmanship by a qualified auto electrician or electronics technician, provided such person and work is approved by Redarc prior to commencement. Subject to **clause 2**, Redarc Electronics is hereby excluded to the maximum extent permitted by law from all other liability in respect of the Product.
- 6-4-2. While Redarc Electronics warrants, where applicable, that the Product is free from defects in materials and workmanship under normal use at the time of delivery, Redarc Electronics does not warrant that the Product will meet any user specific requirements or that the operation of the Product will be uninterrupted or error-free.

6-5. Owner's Responsibilities

- 6-5-1. Maintenance of the Product and associated equipment and/or machinery is the responsibility of the owner. The owner must retain evidence that proper maintenance has been performed on the Product by Redarc Electronics or a qualified auto electrician or electronics technician. Claims made during the warranty term will not be accepted if resulting from lack of maintenance rather than faulty material or workmanship.
- 6-5-2. The owner must operate the Product in accordance with all of the Operating Instructions.
- 6-5-3. Upon discovery of a fault the owner must return the Product to the distributor with full details of the nature of the fault. Removal of the Product must be done by a qualified auto electrician or electronics technician to ensure that the warranty remains valid. A written report describing the circumstances of failure must accompany the returned Product with proof of purchase which clearly shows the date of such purchase by the original purchaser.
- 6-5-4. If the Product is found to be working satisfactorily on return to Redarc Electronics a reasonable charge will be made for the cost of testing, packing and freight. The Product will be returned on receipt of the amount charged.



23 Brodie Road North
Lonsdale SA 5160
Phone 08 8322 4848
Fax 08 8387 2889
www.redarc.com.au